



Disney · PIXAR
TOY
STORY



7594



2

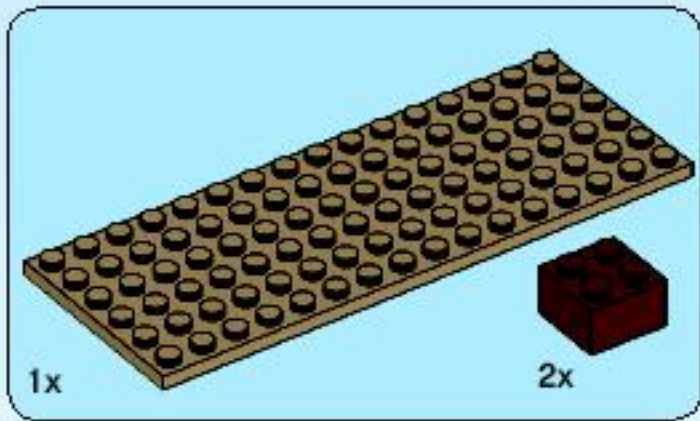
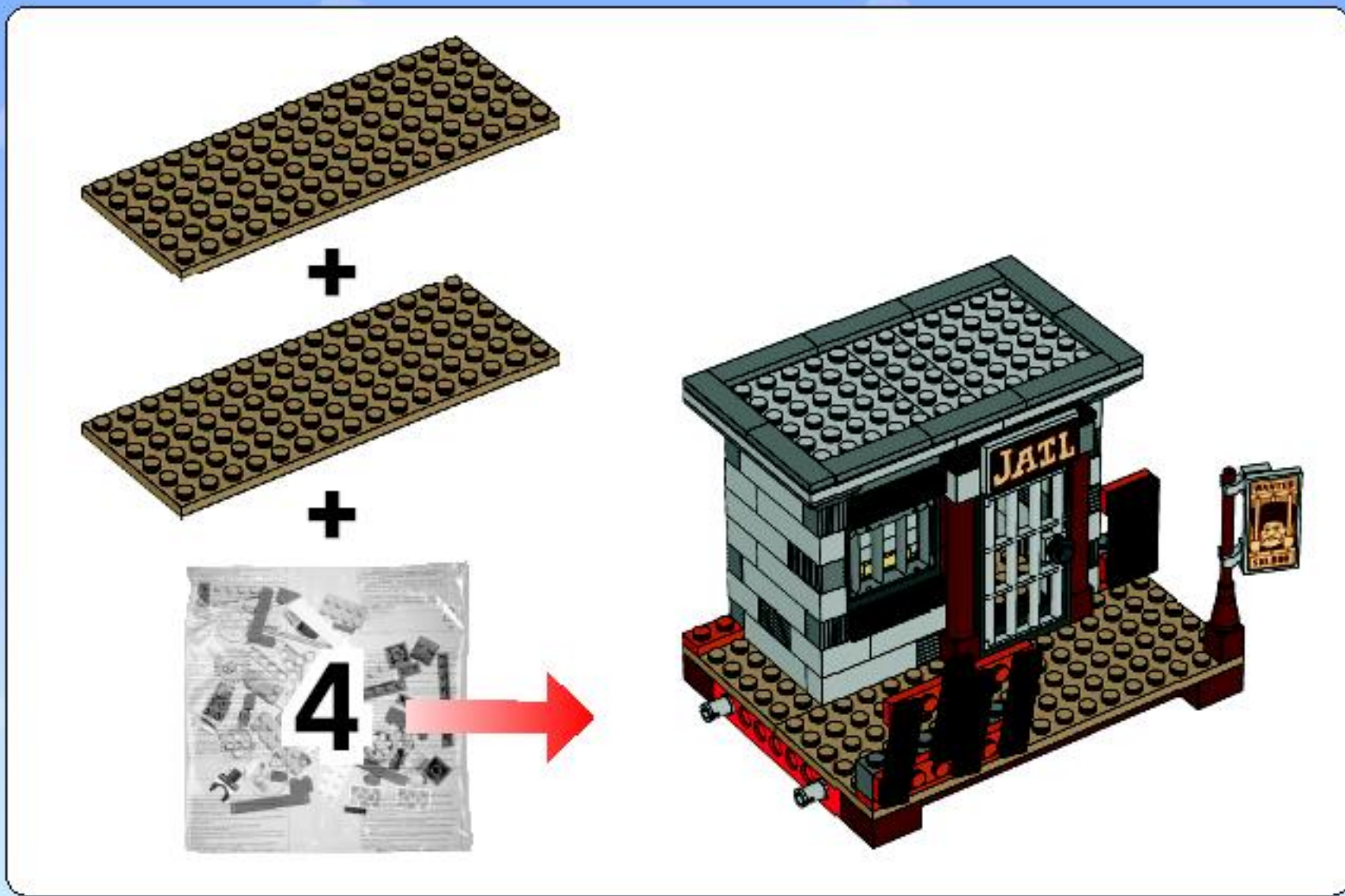

1

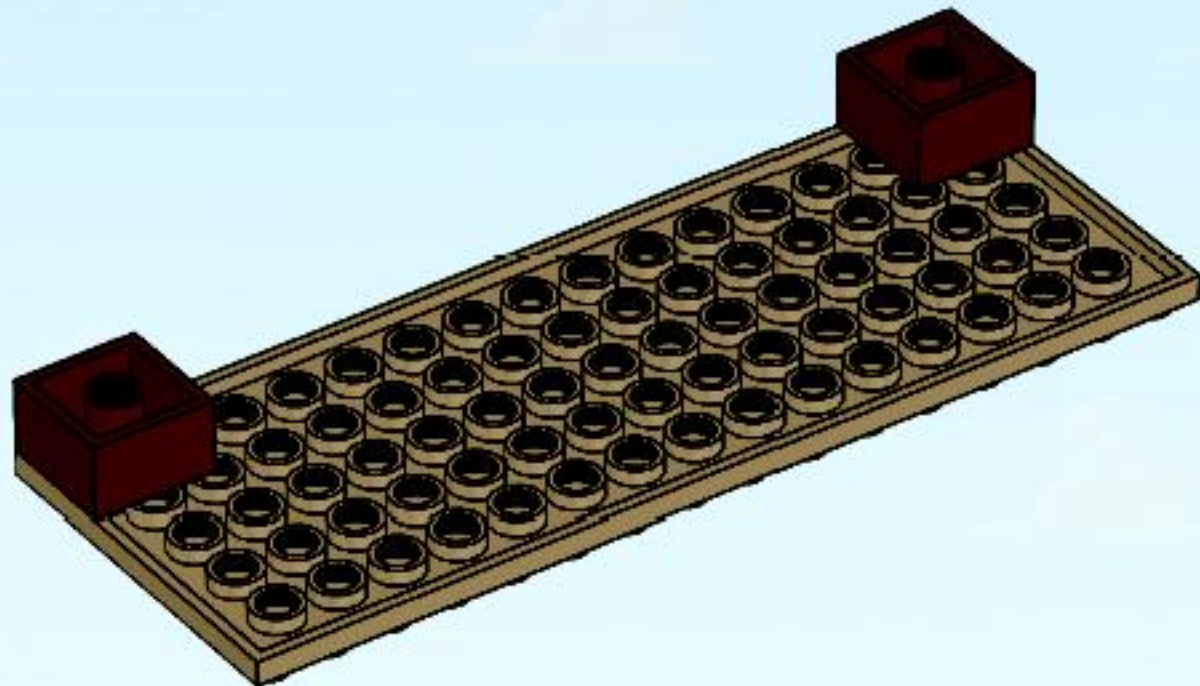

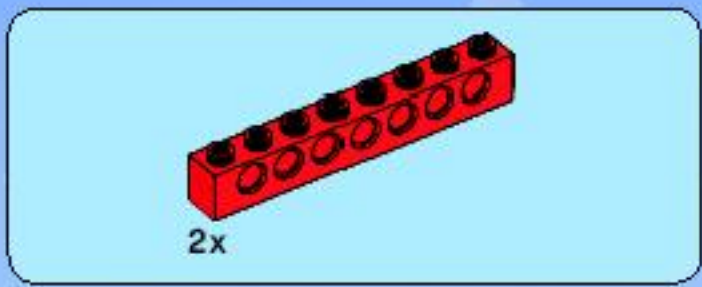

2

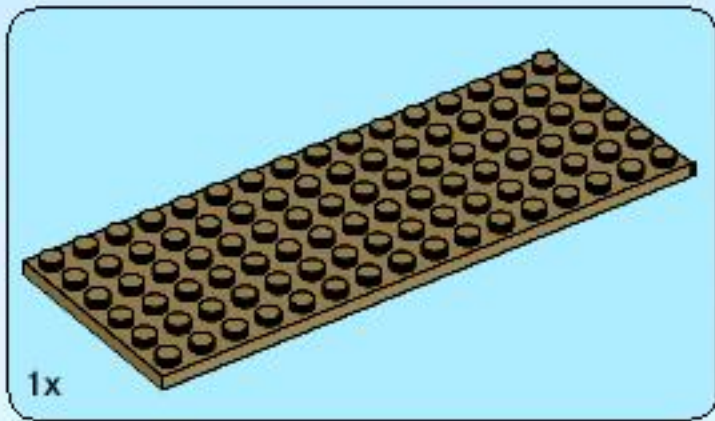
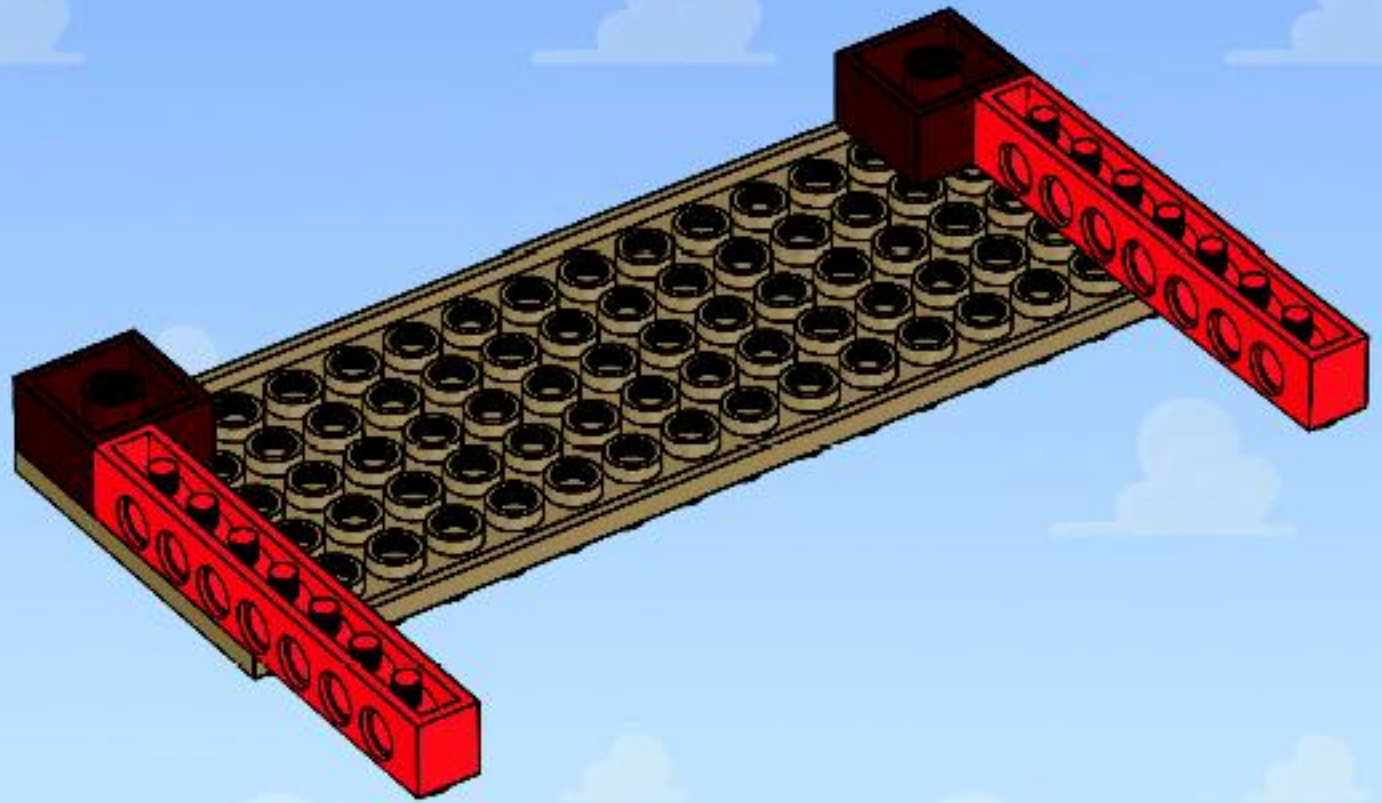

3

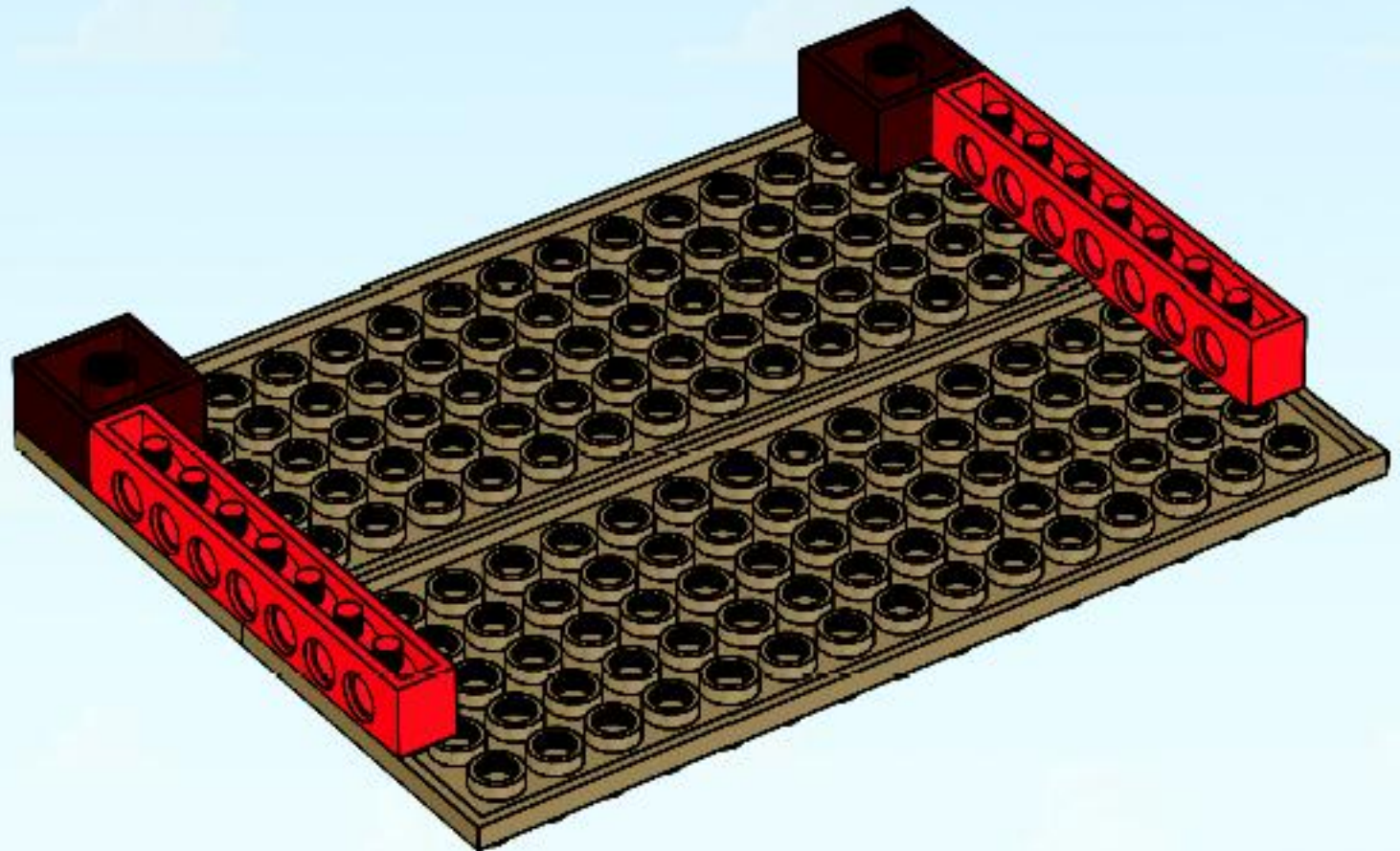



4

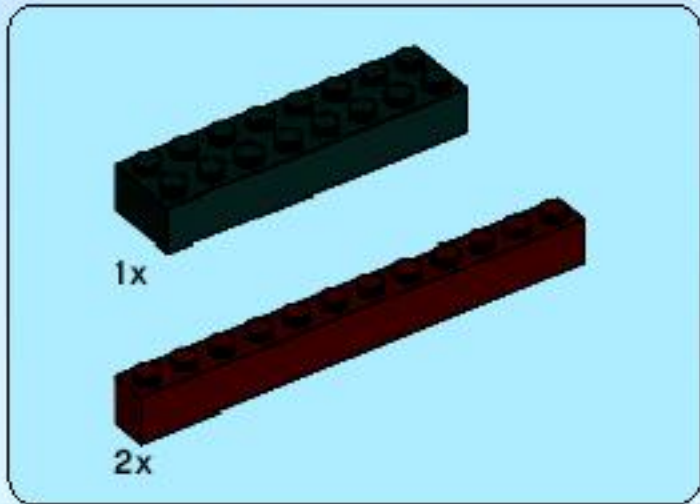
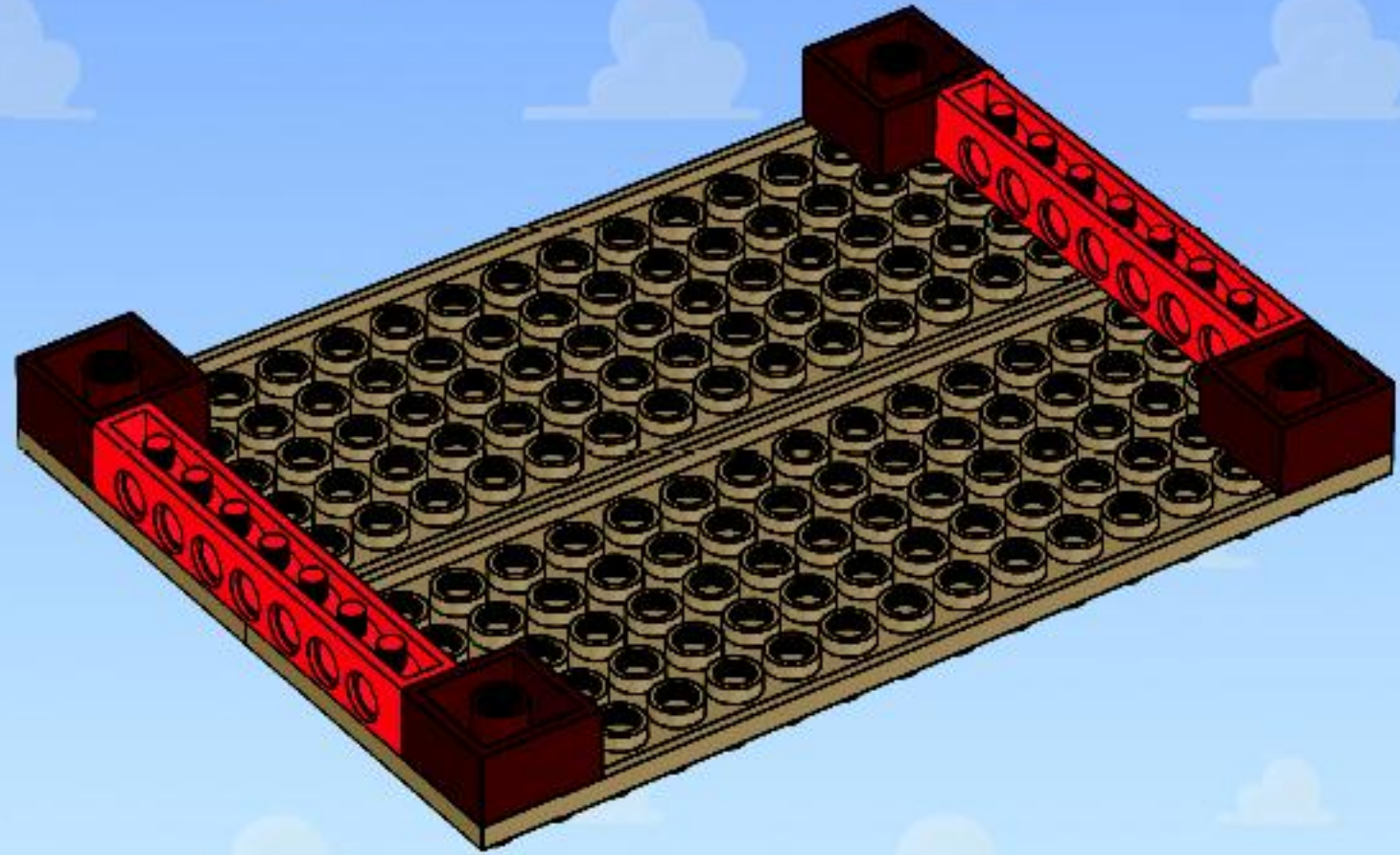

5

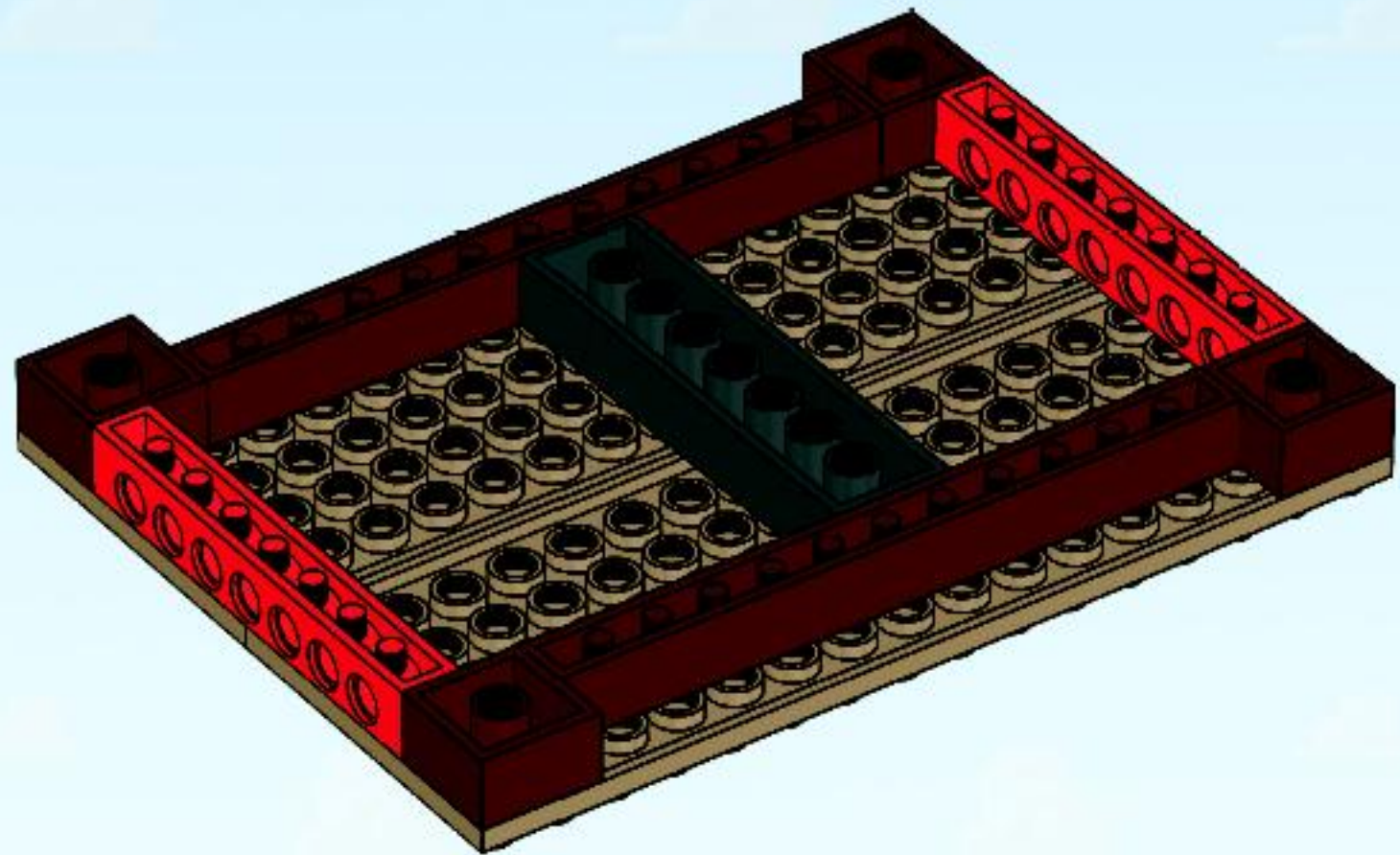

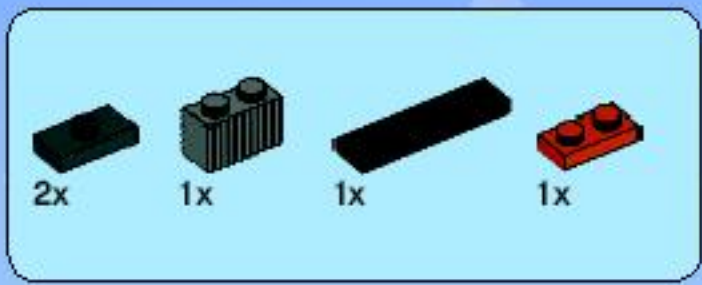

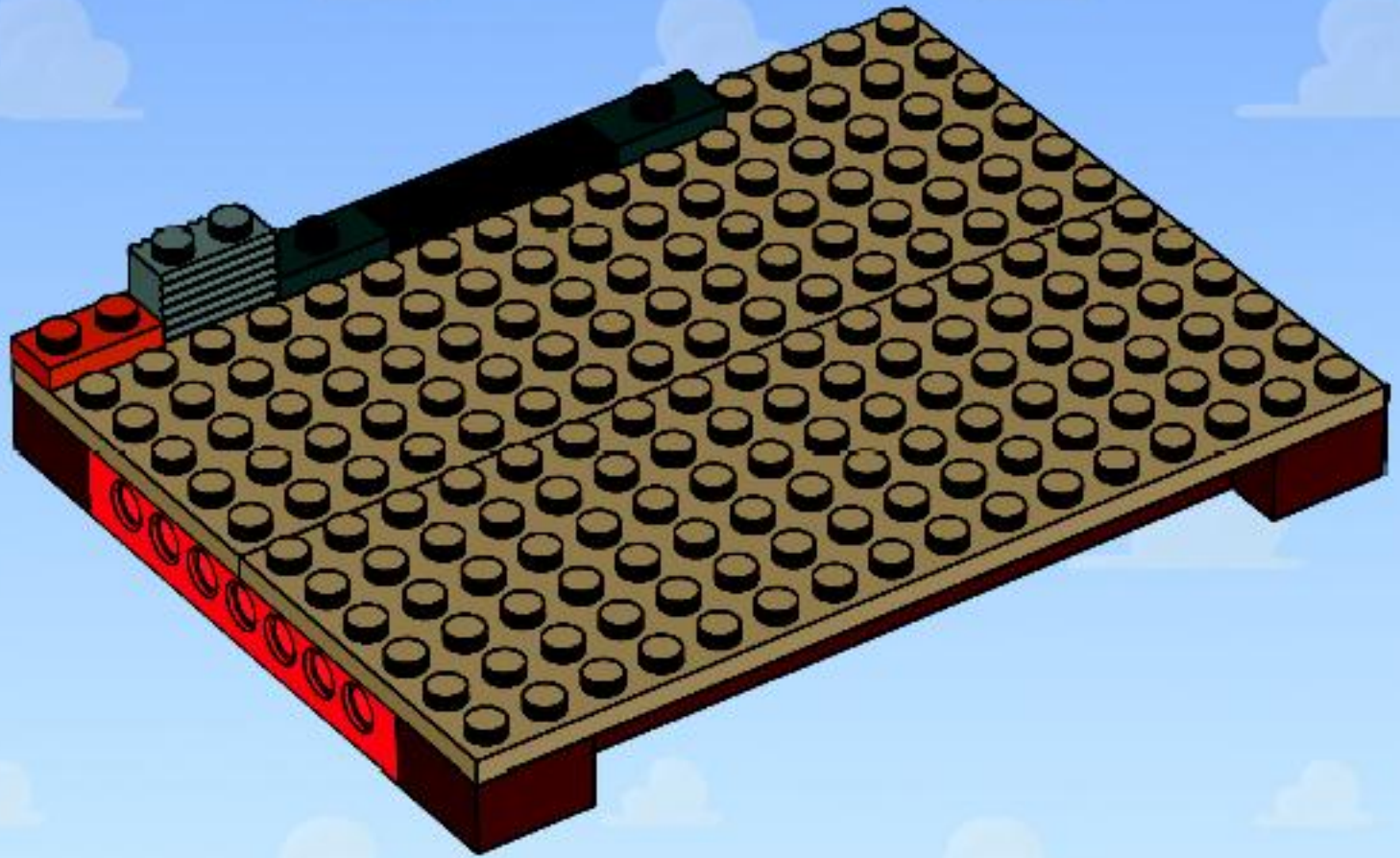

6

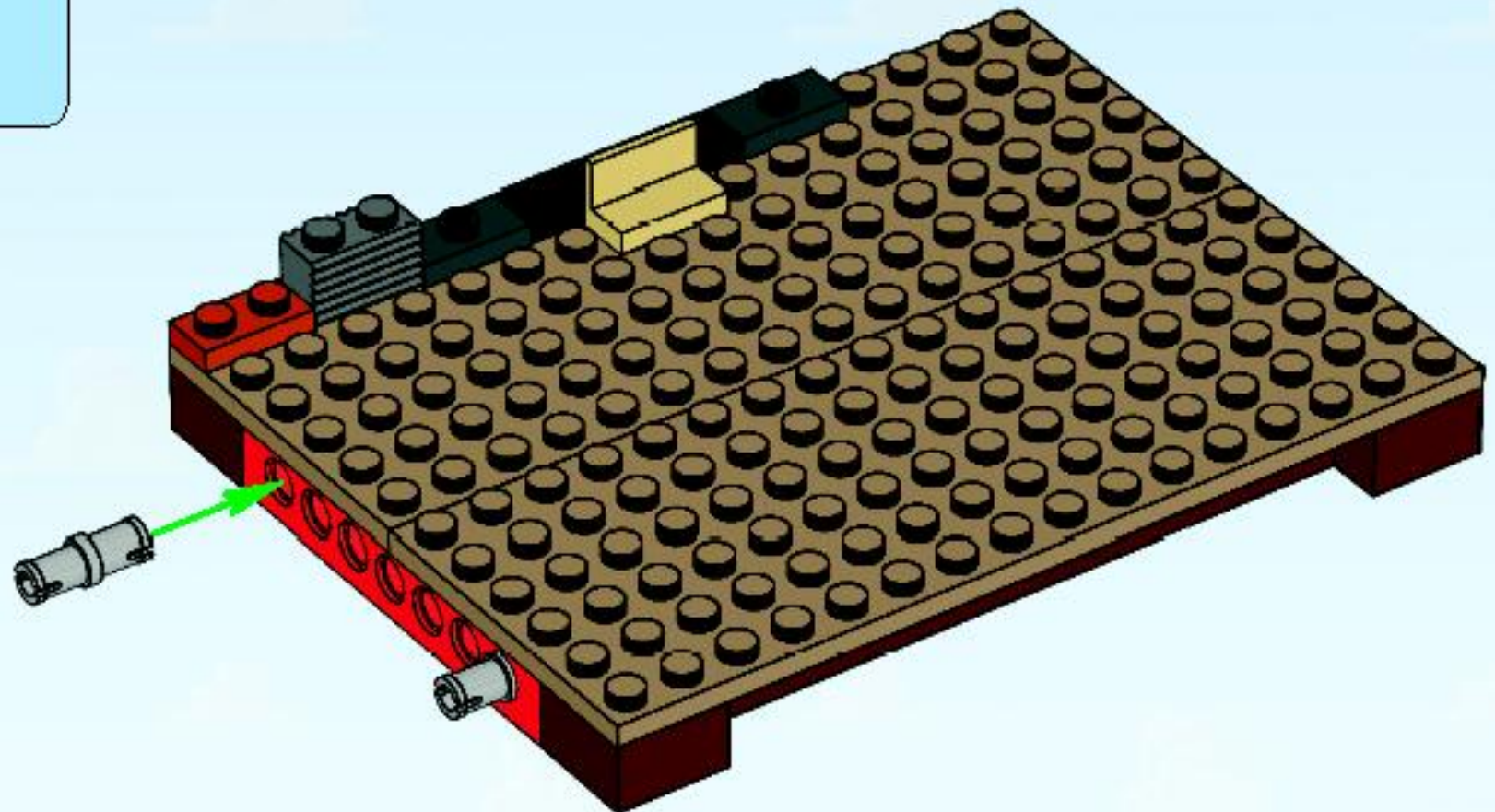

7



1x  2x 

8

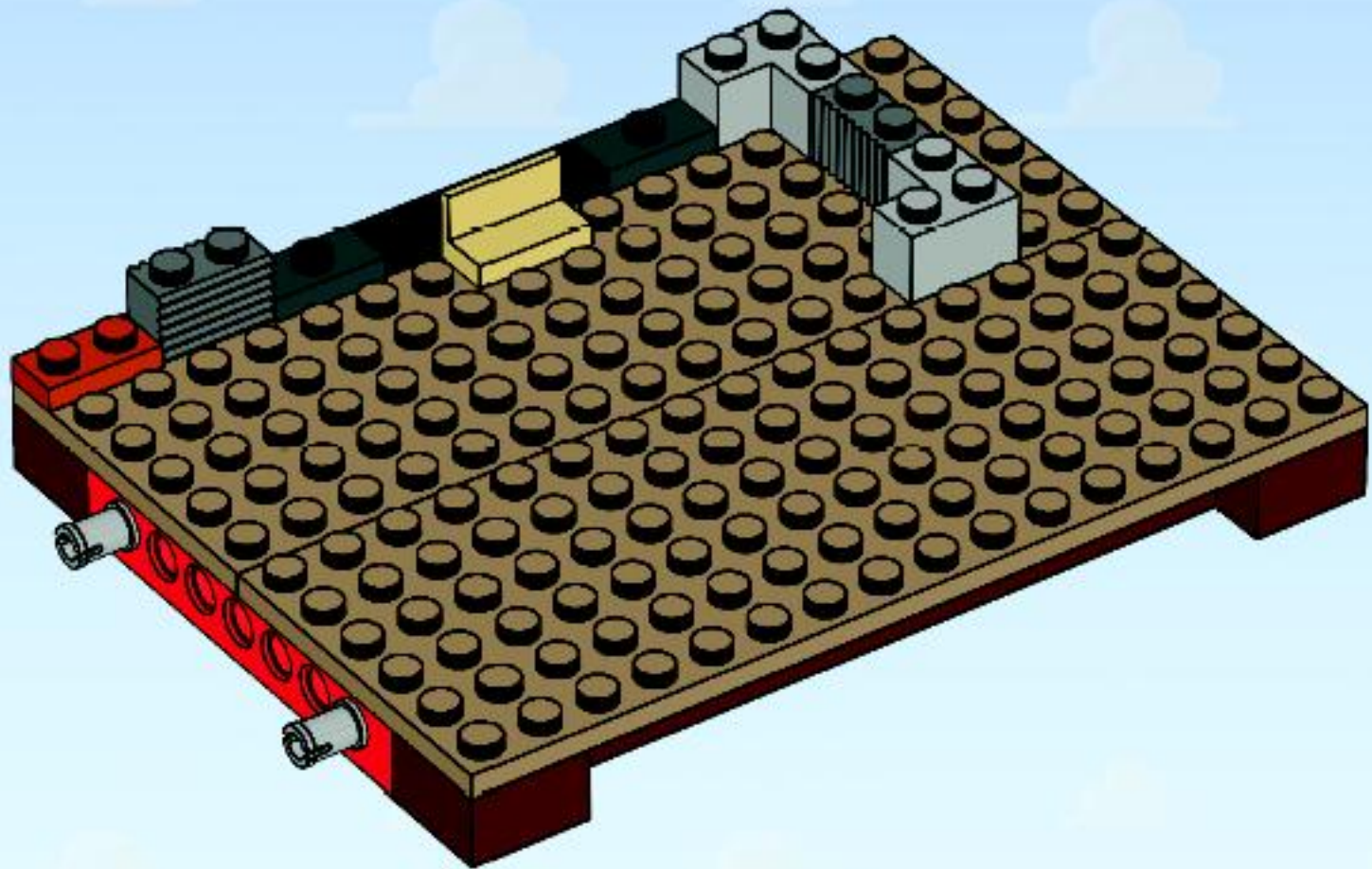

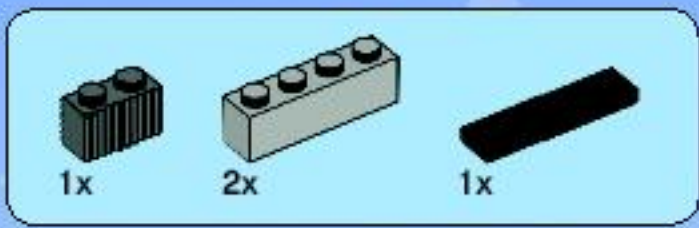

9

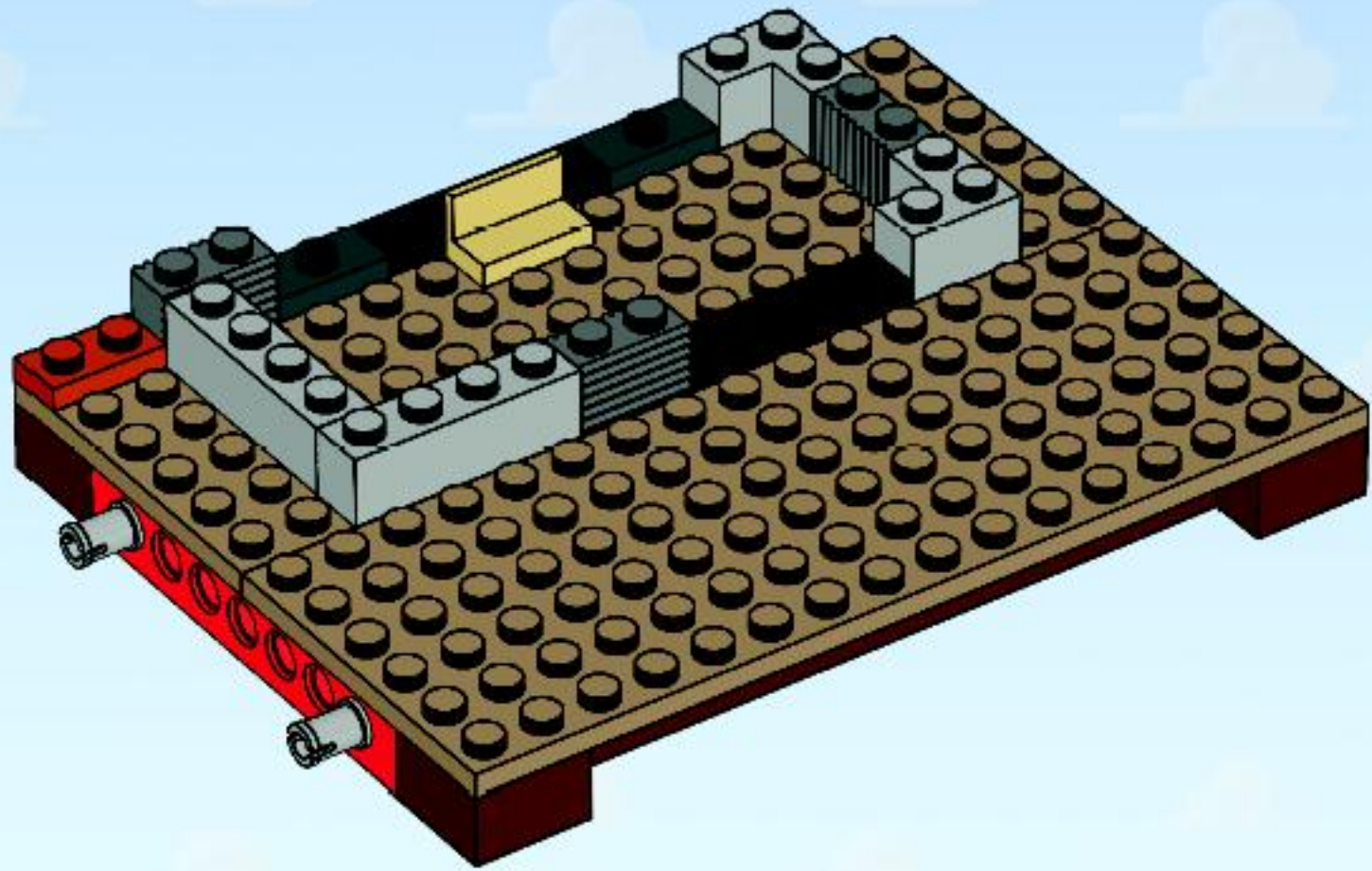

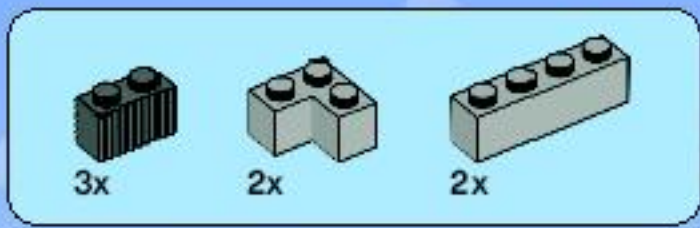

10

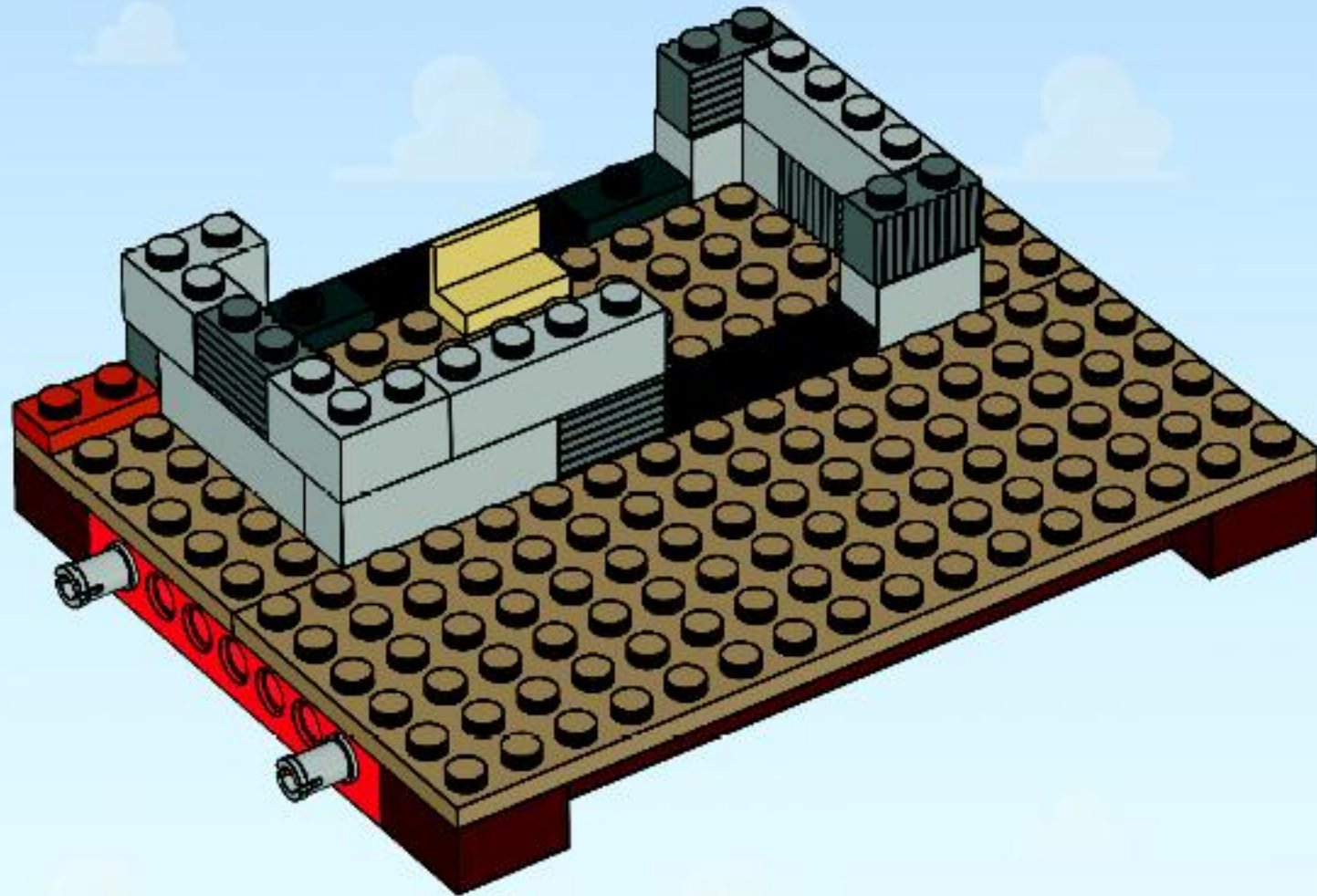

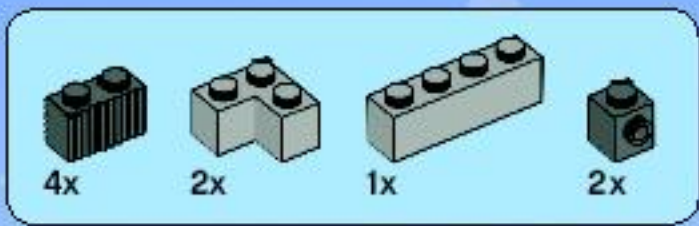

11

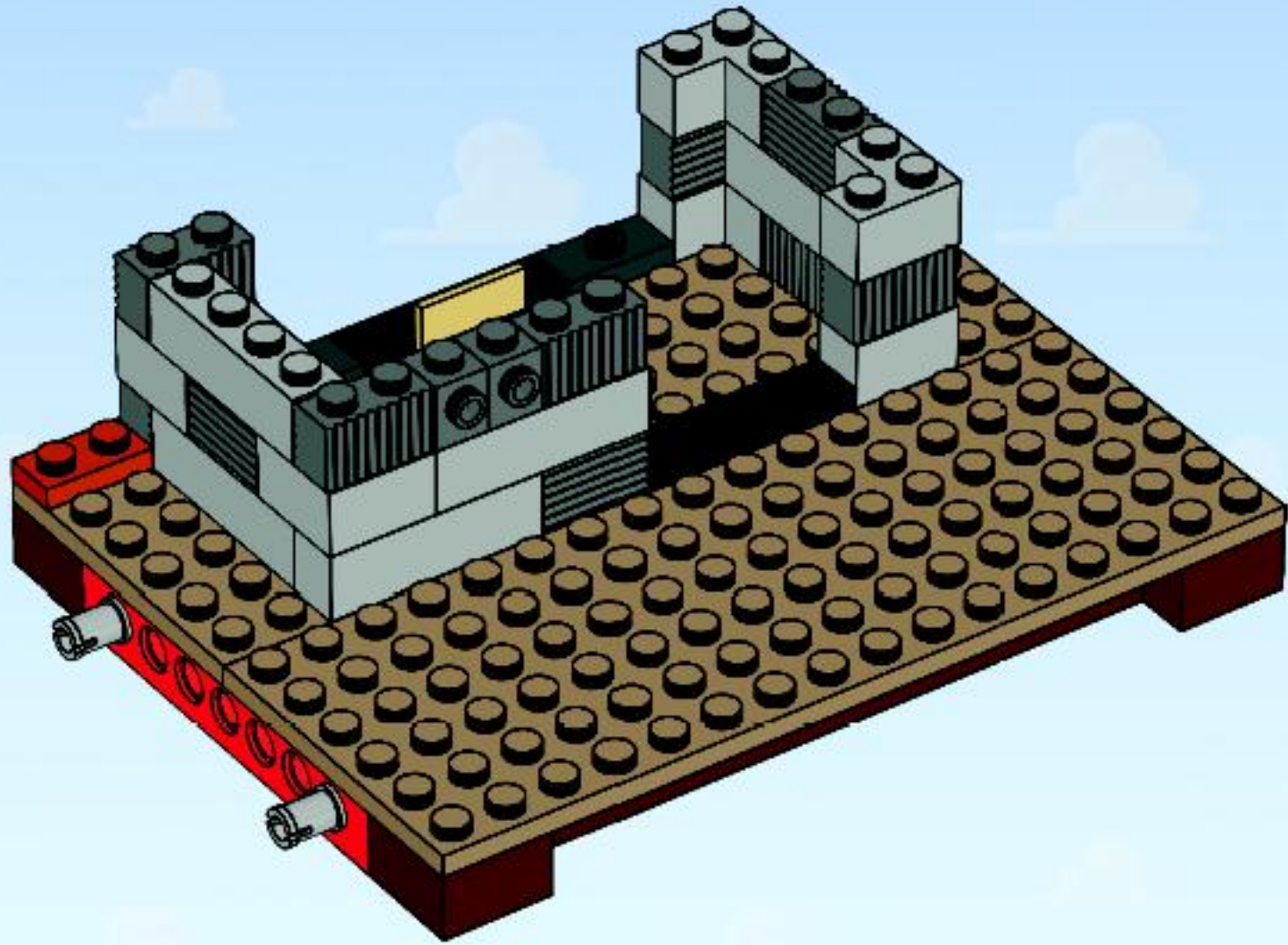

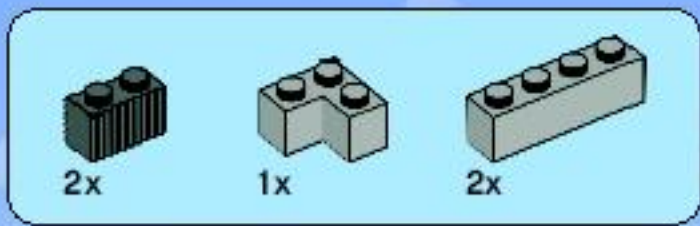

12

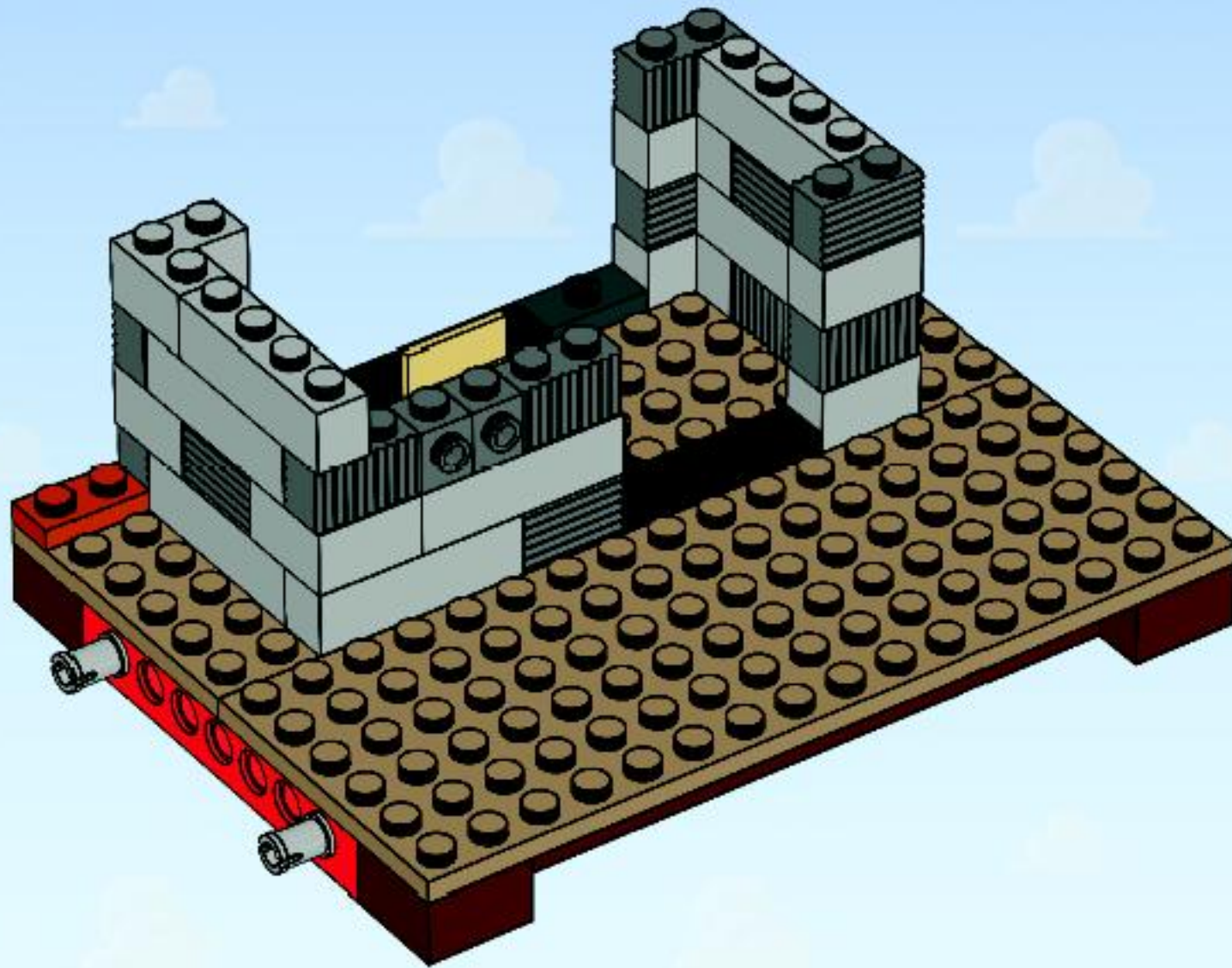

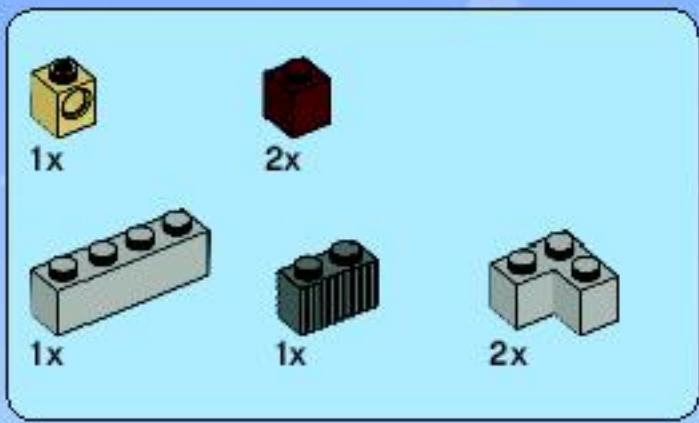

13

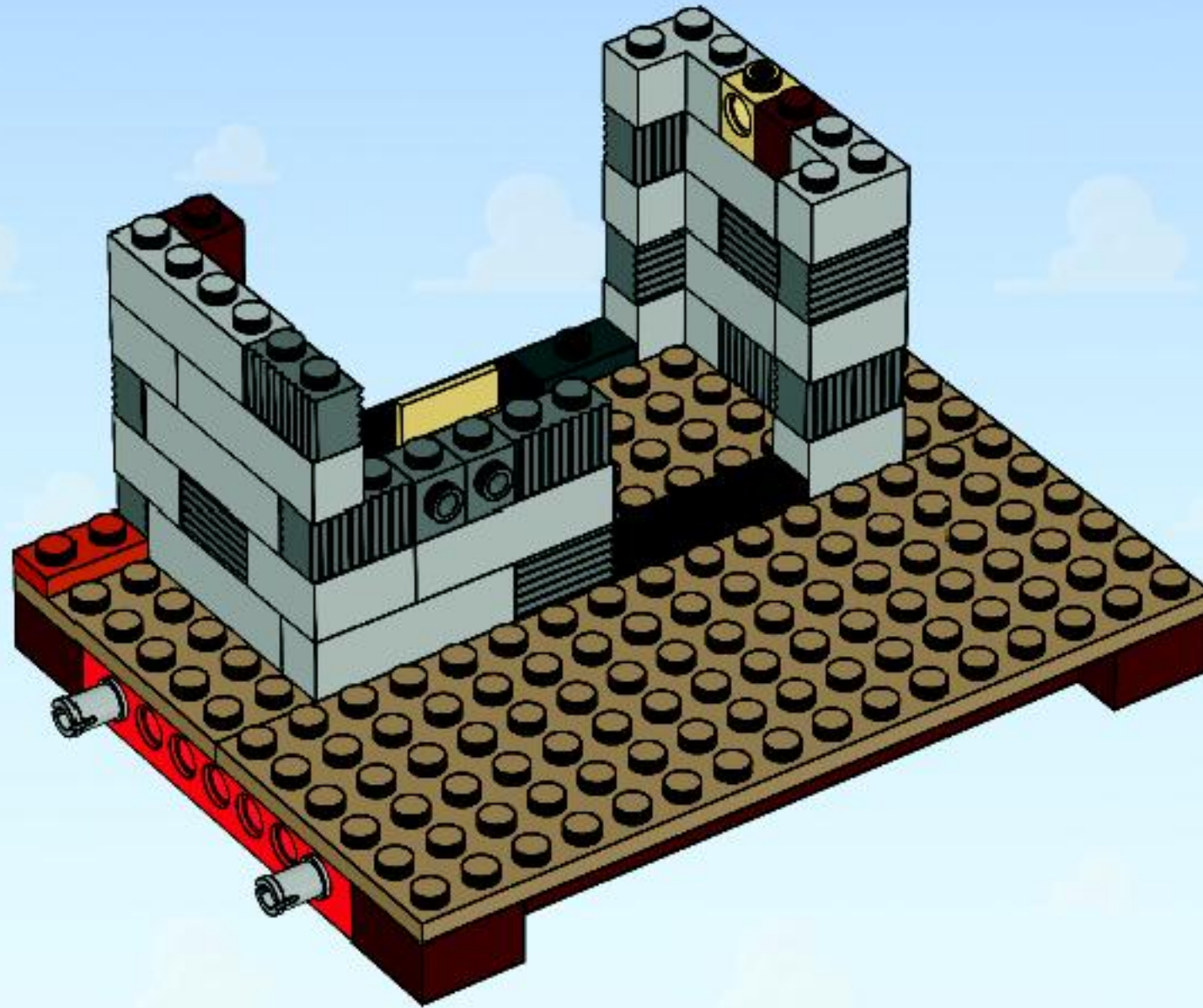

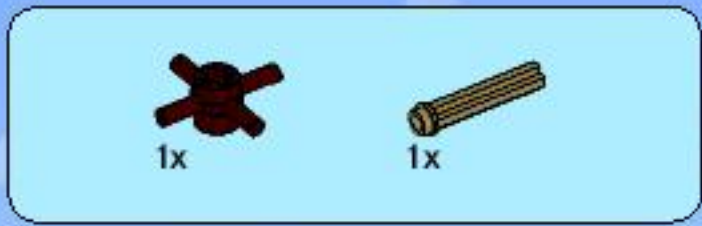

14

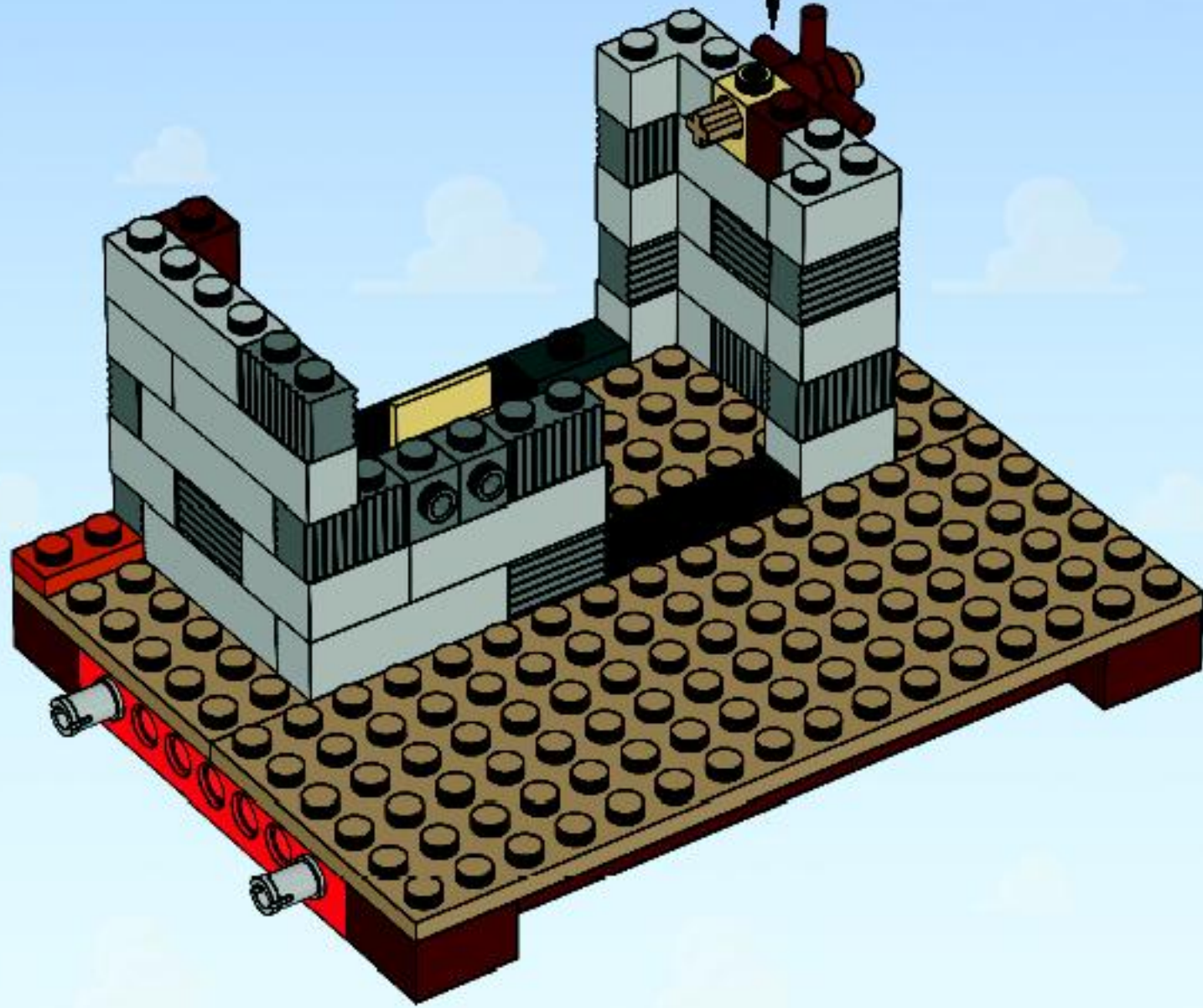
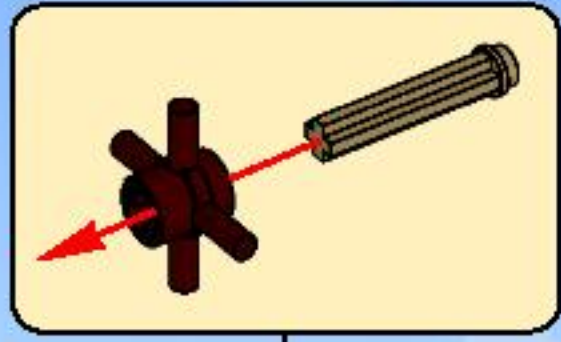



15

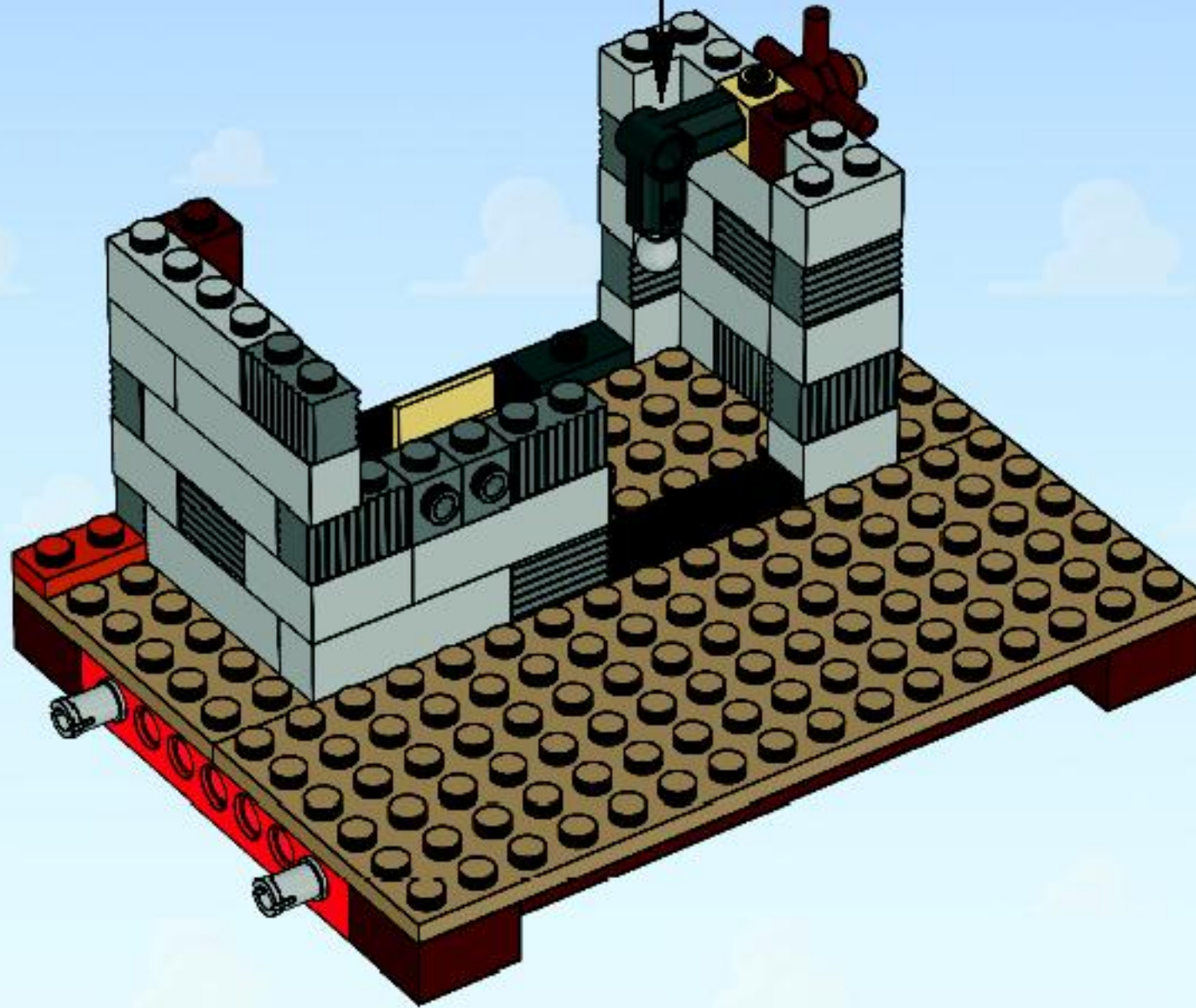
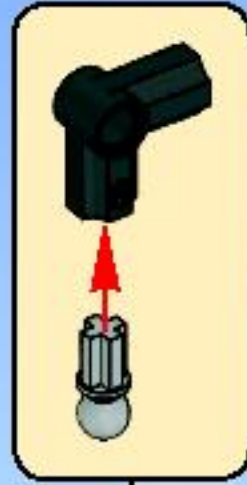



16

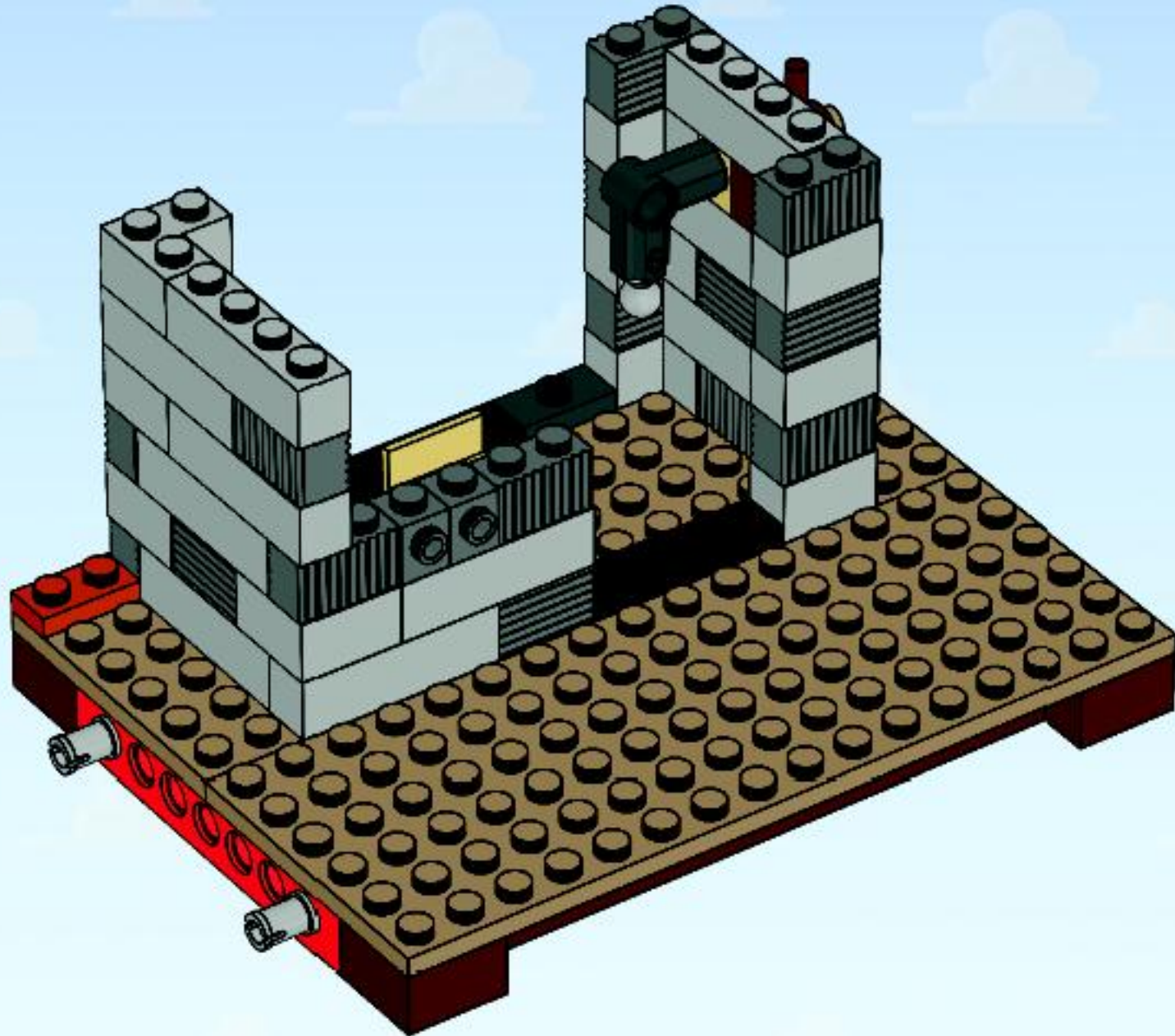

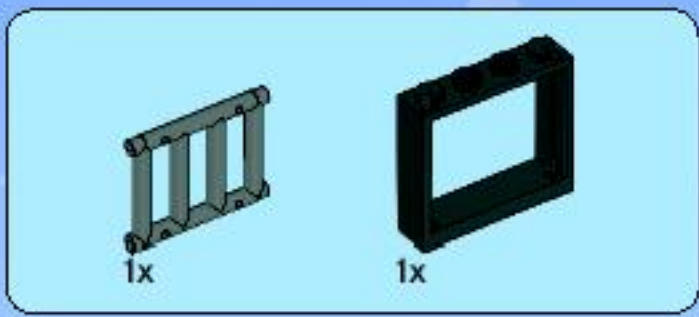

17

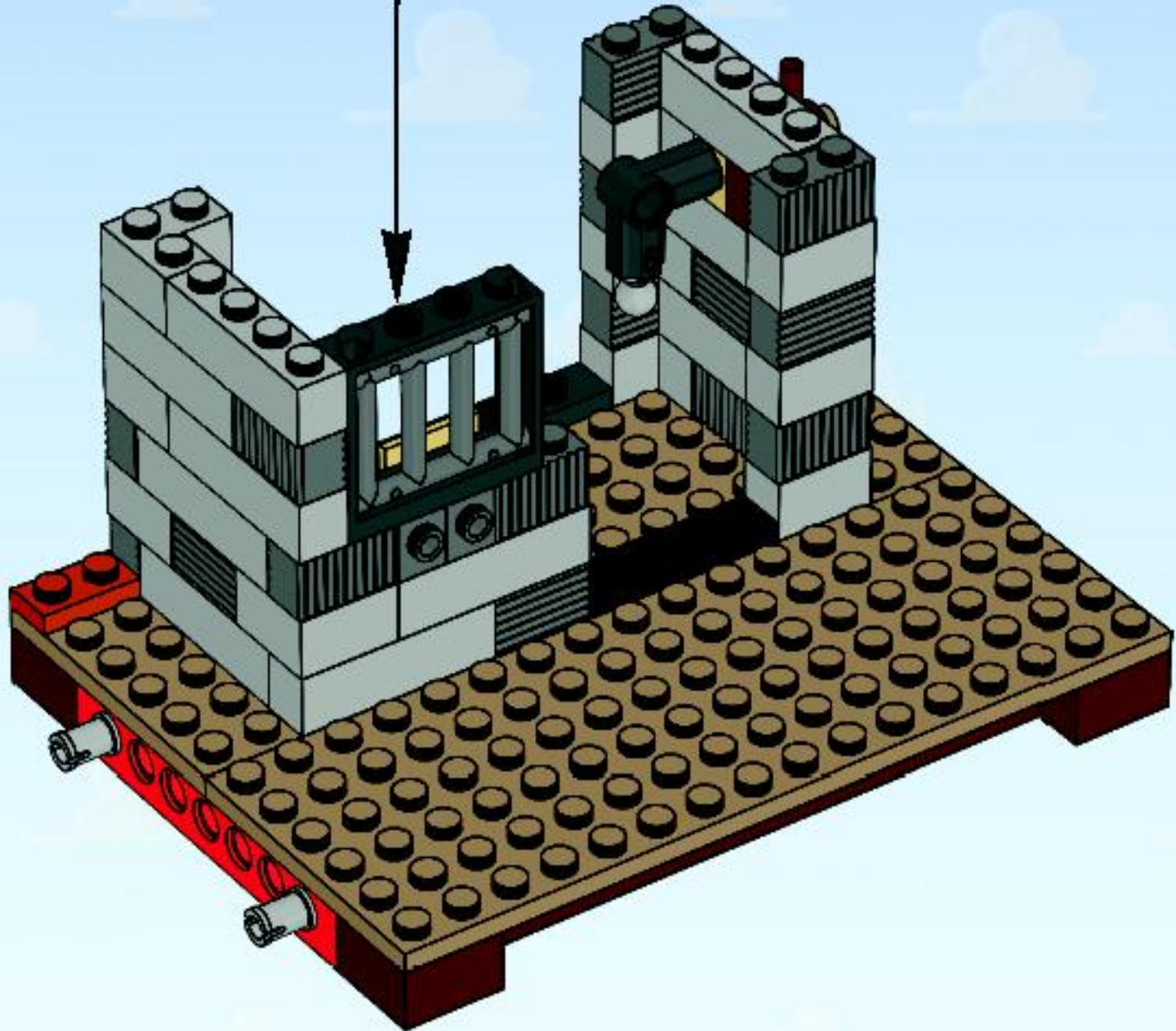
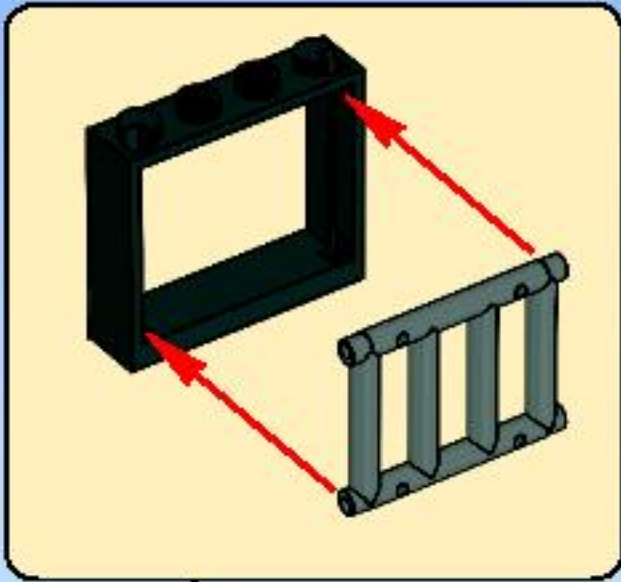



18

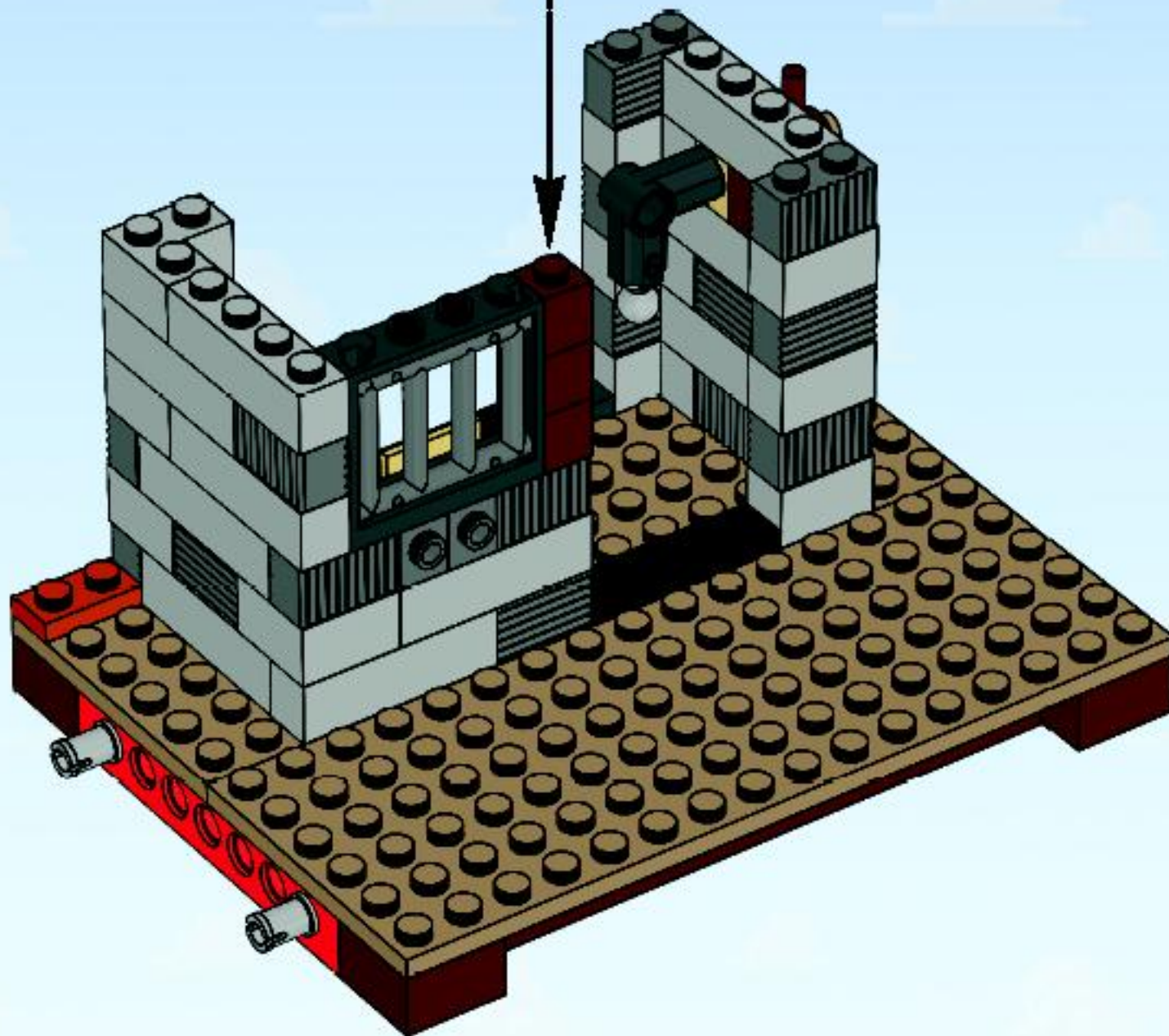
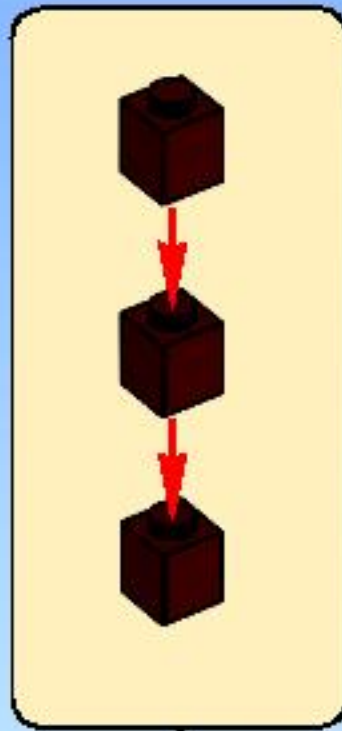

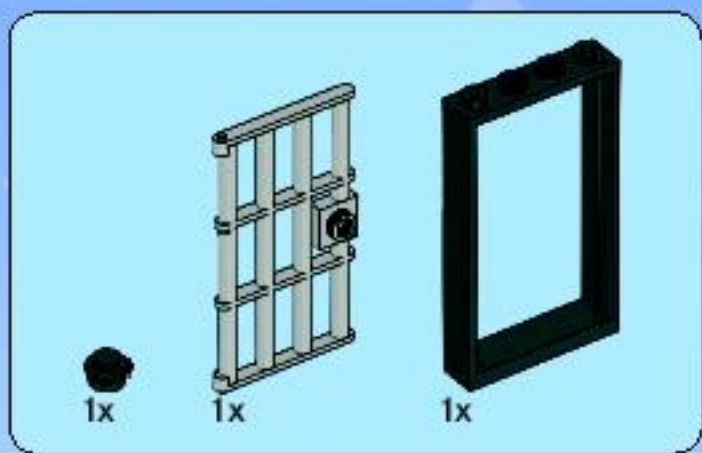

19

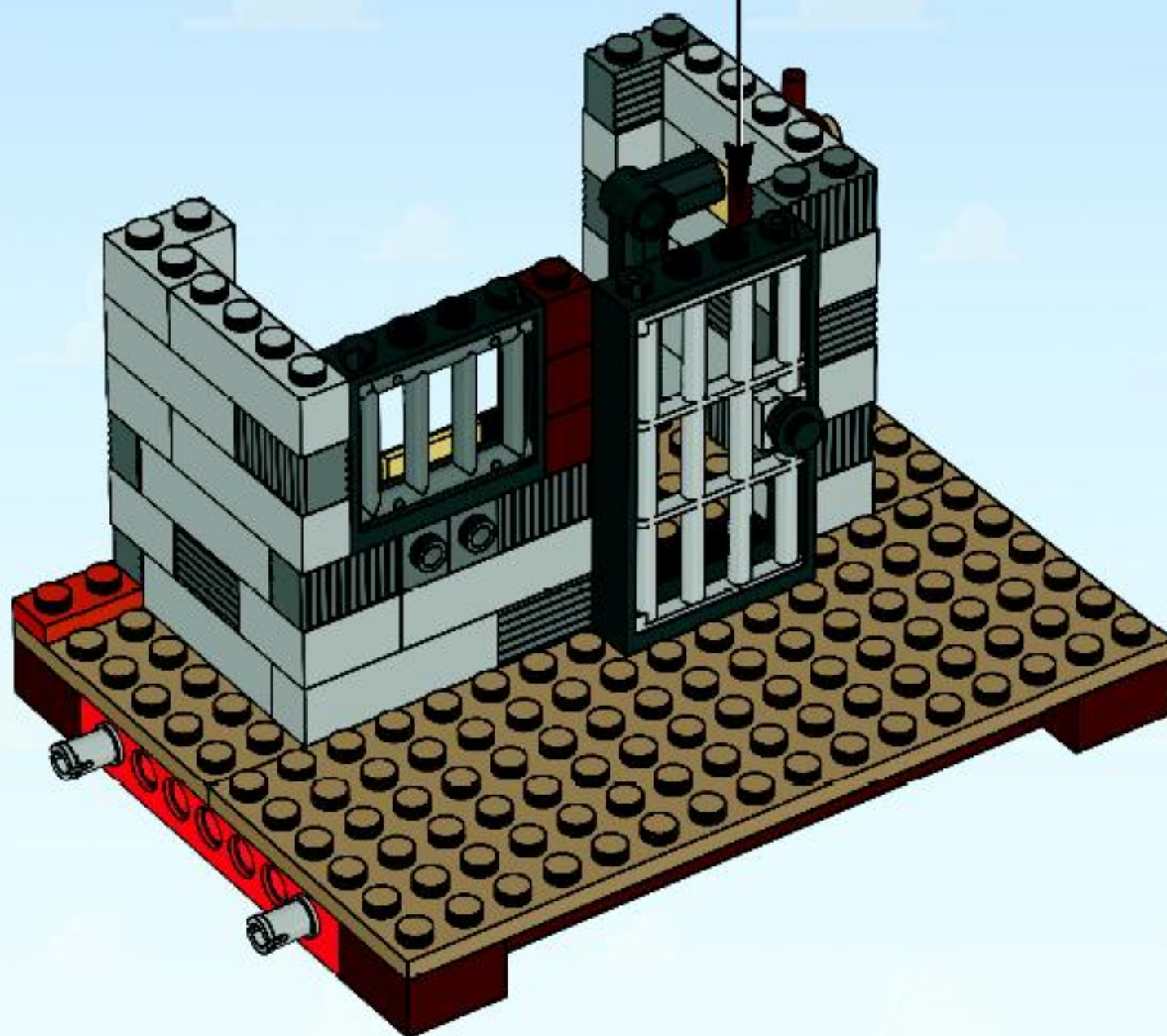
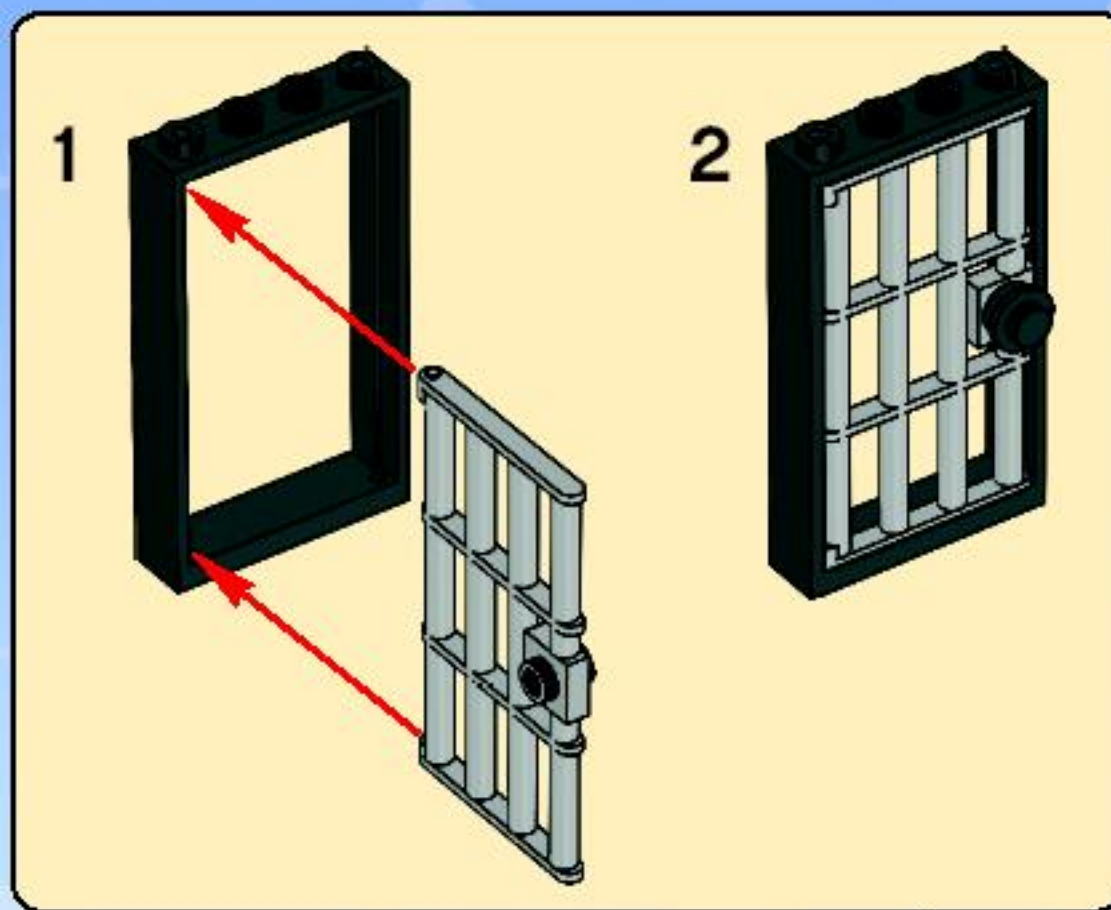

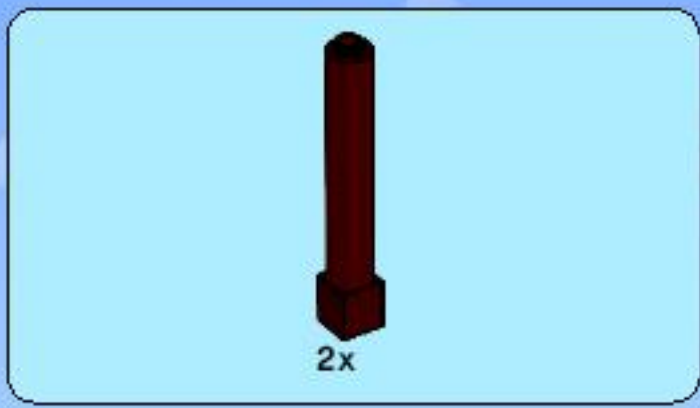

20

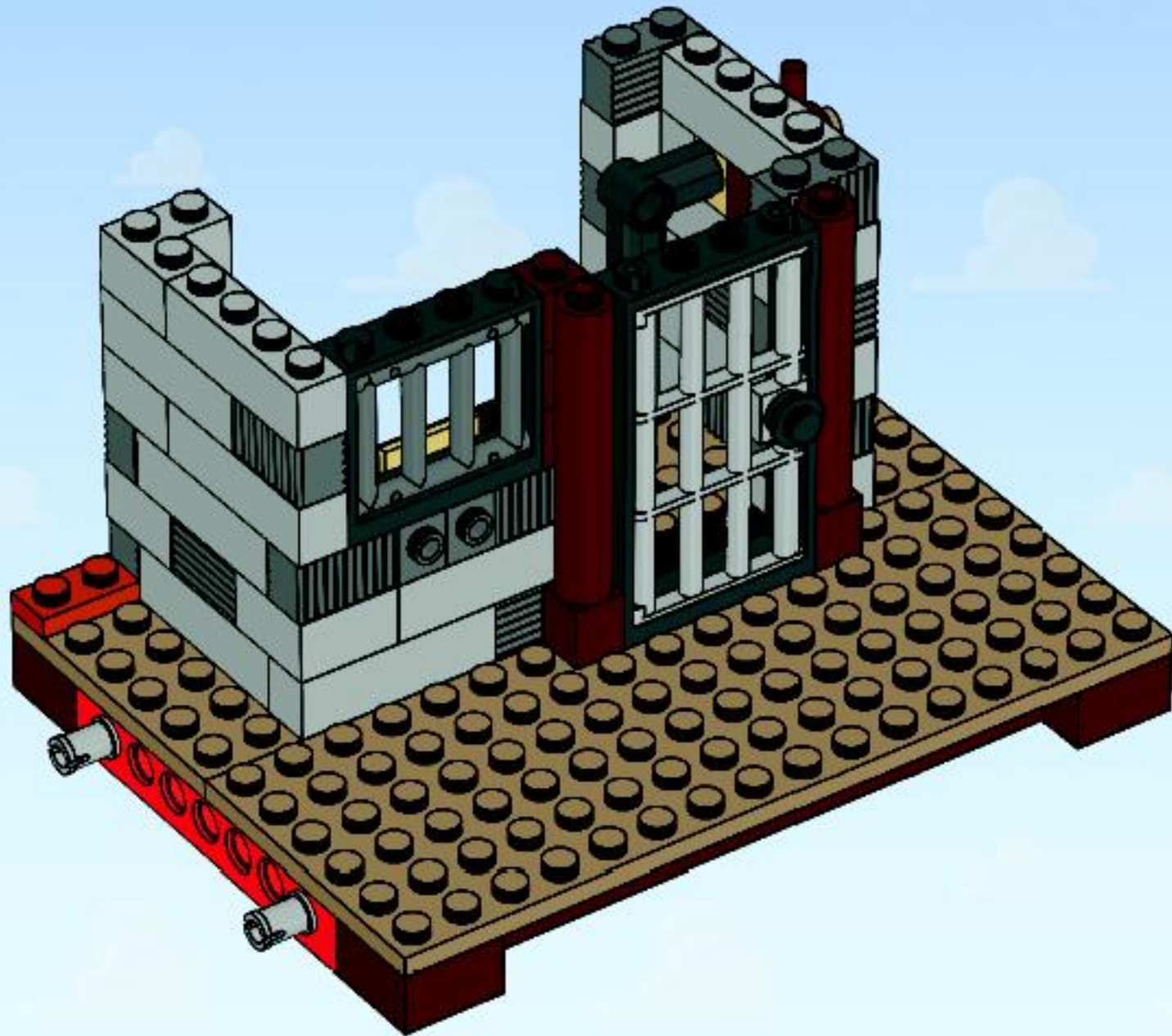

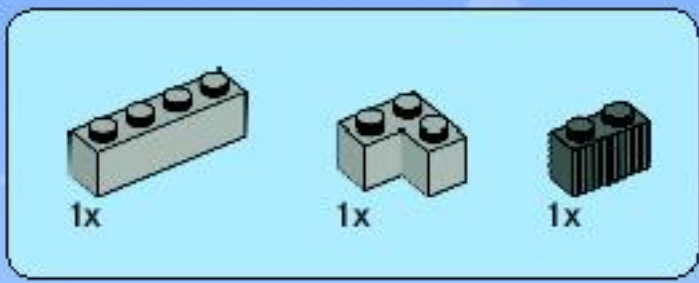

21

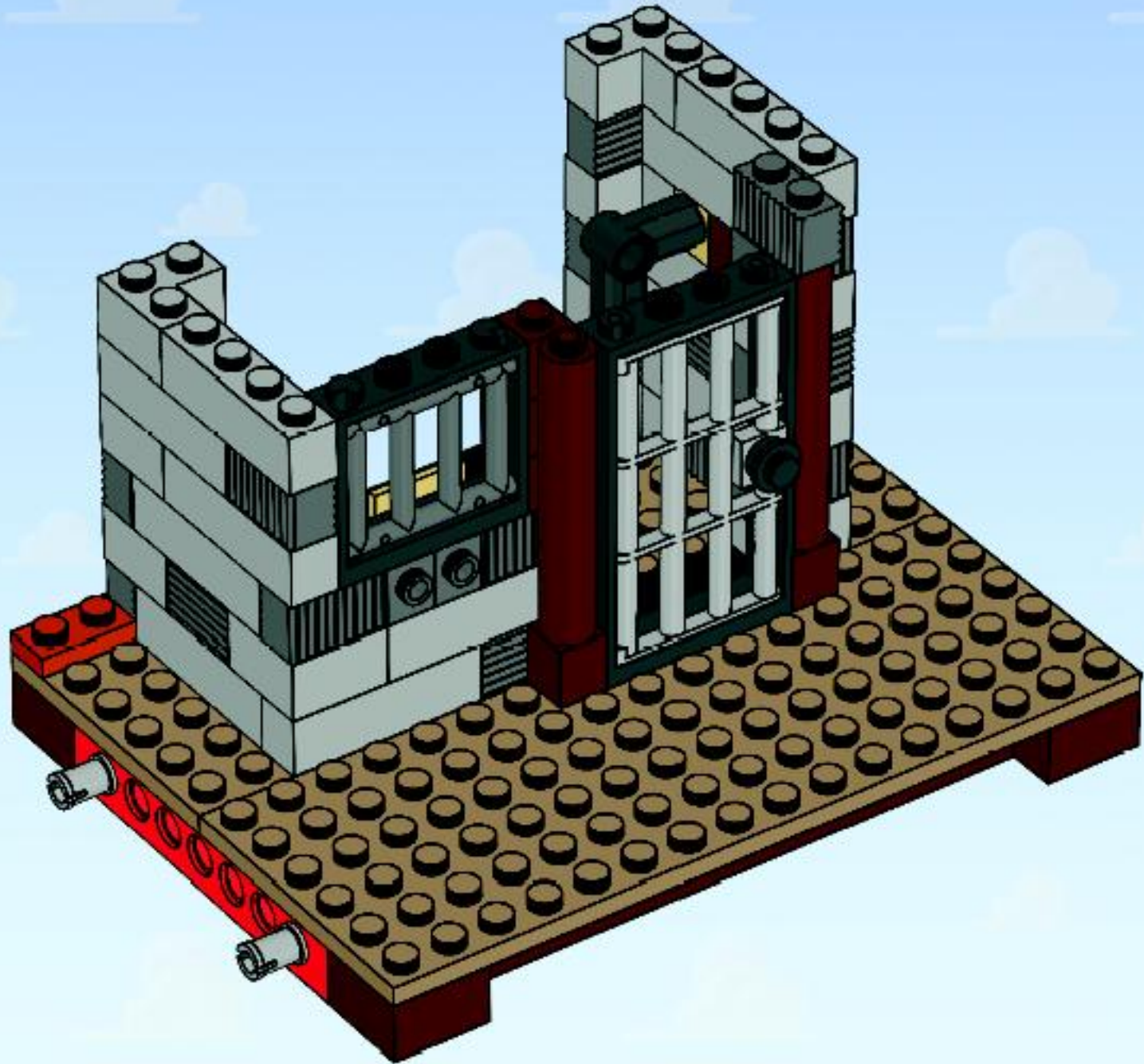

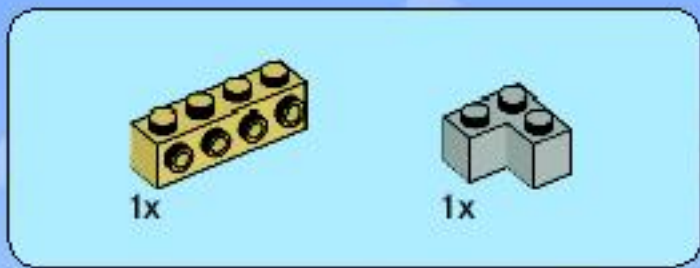

22

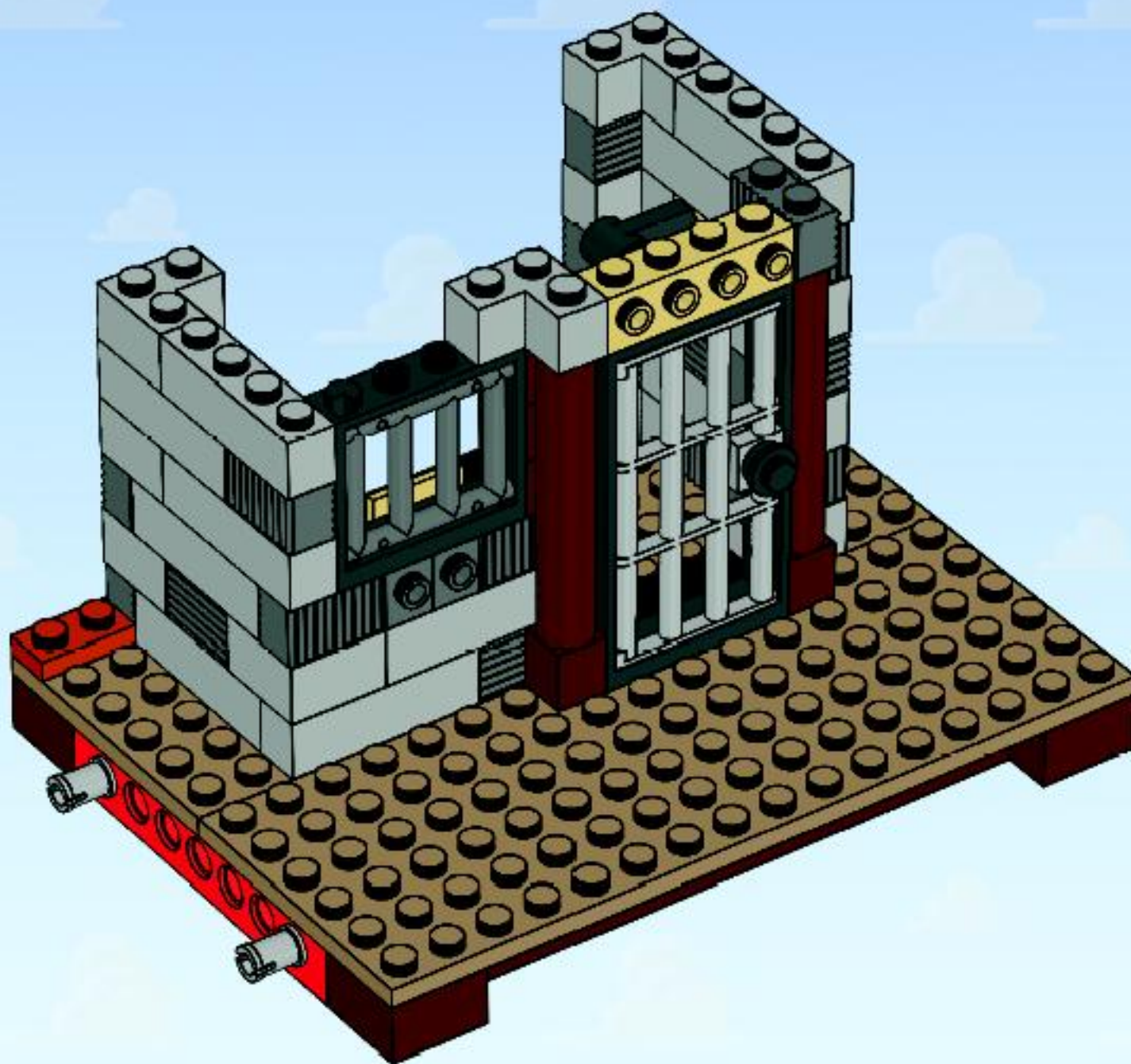

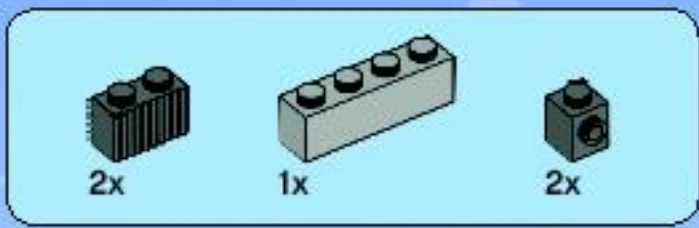

23

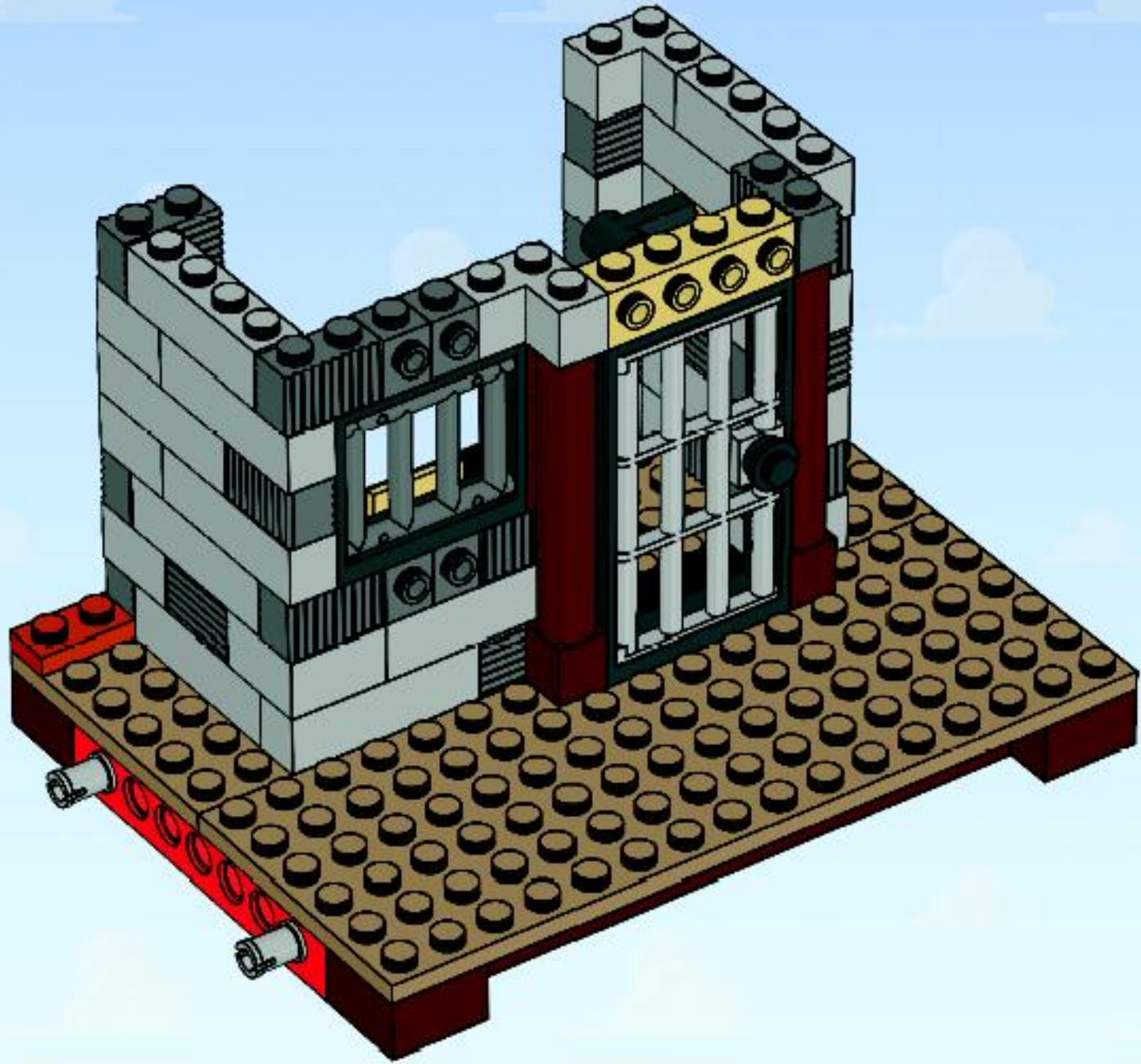



3x

24



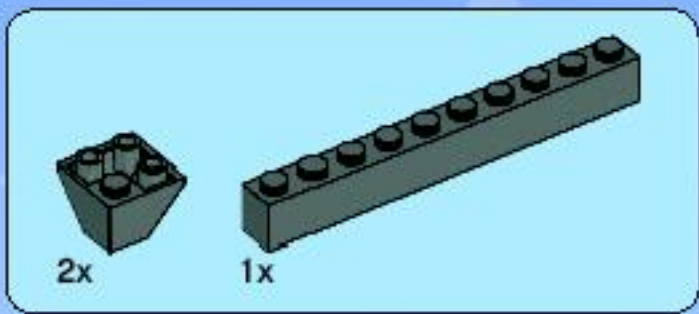

25

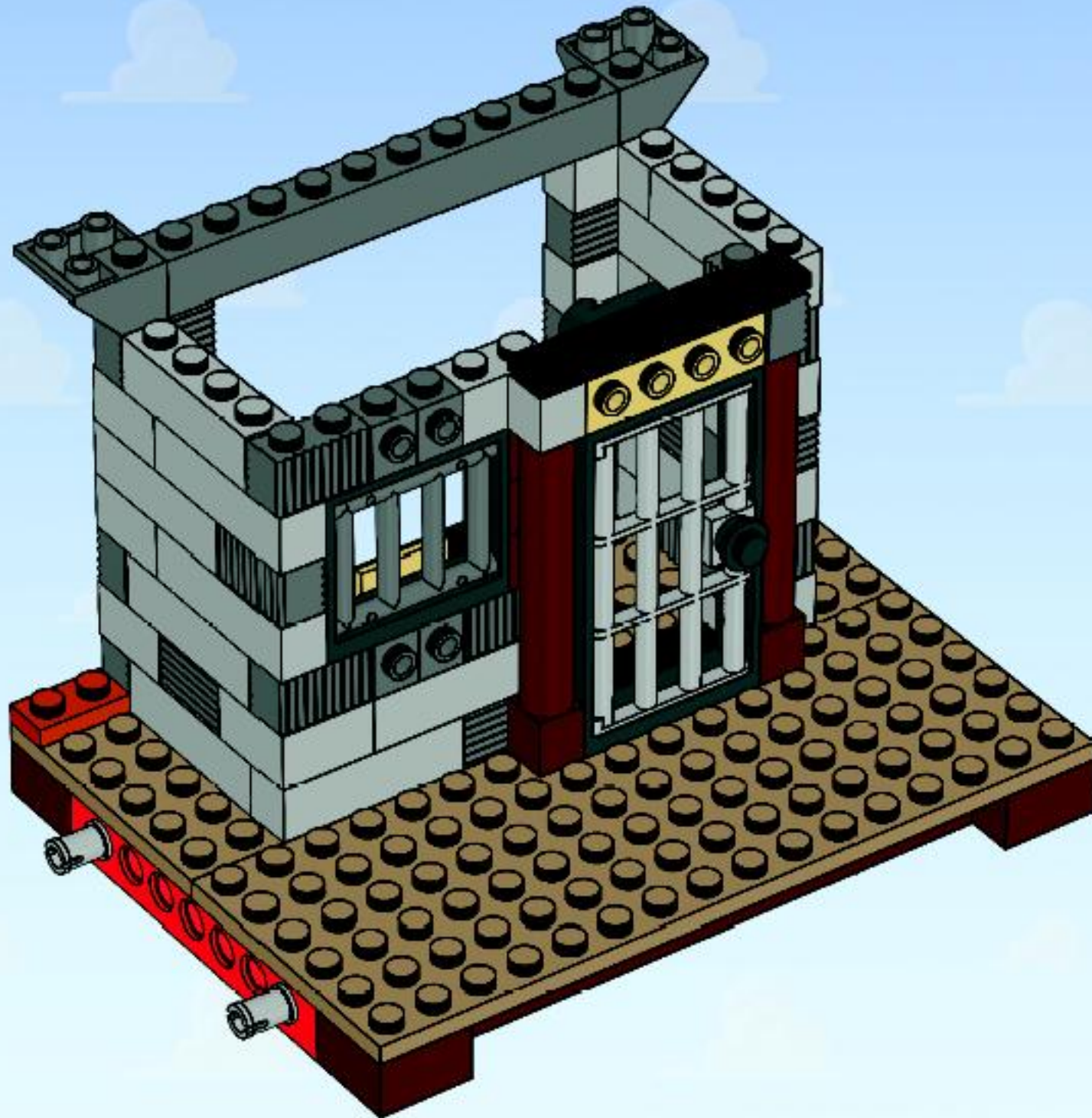



4x

26

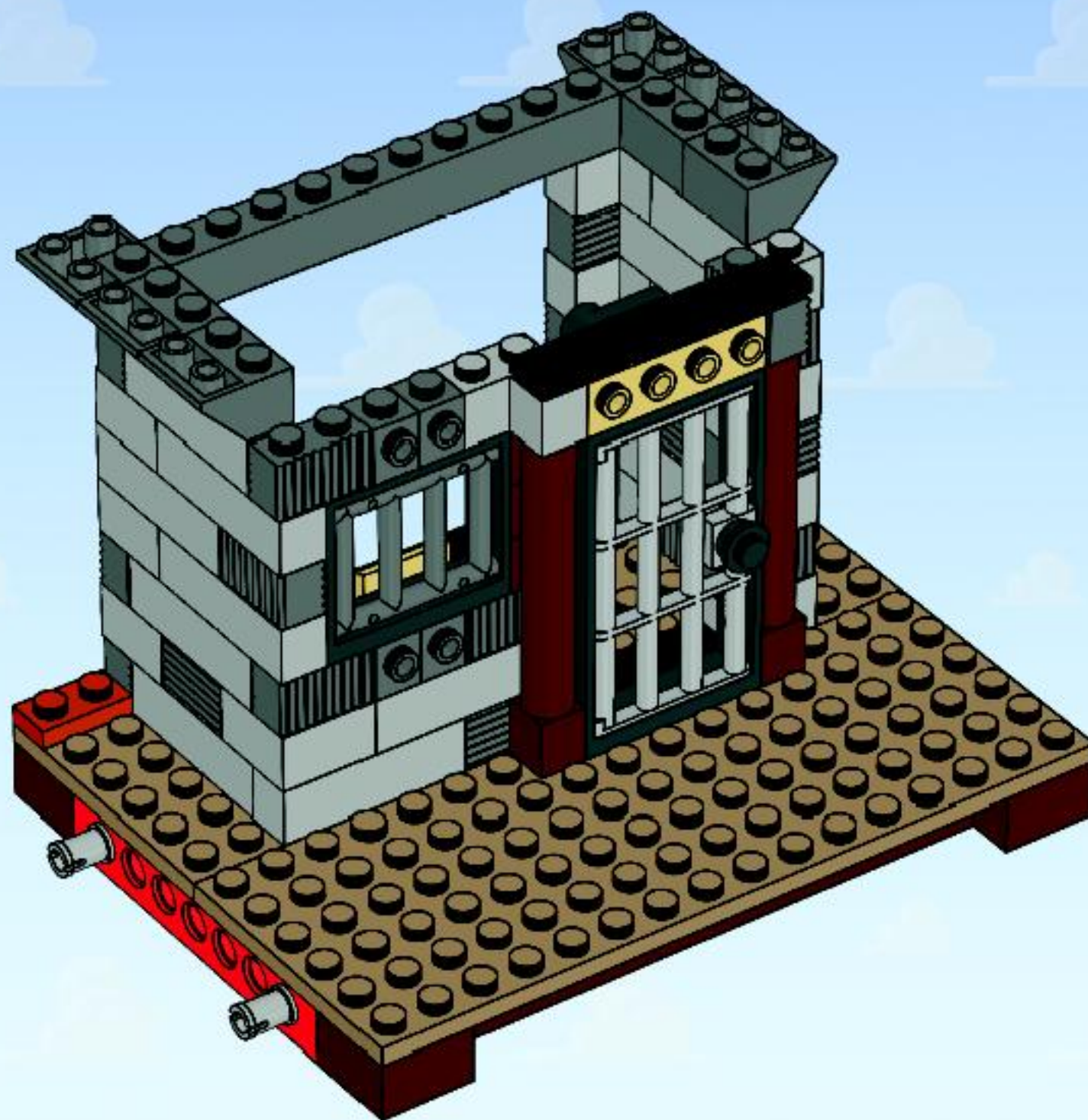

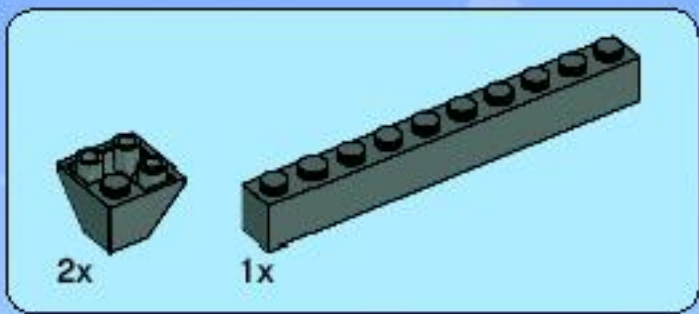

27

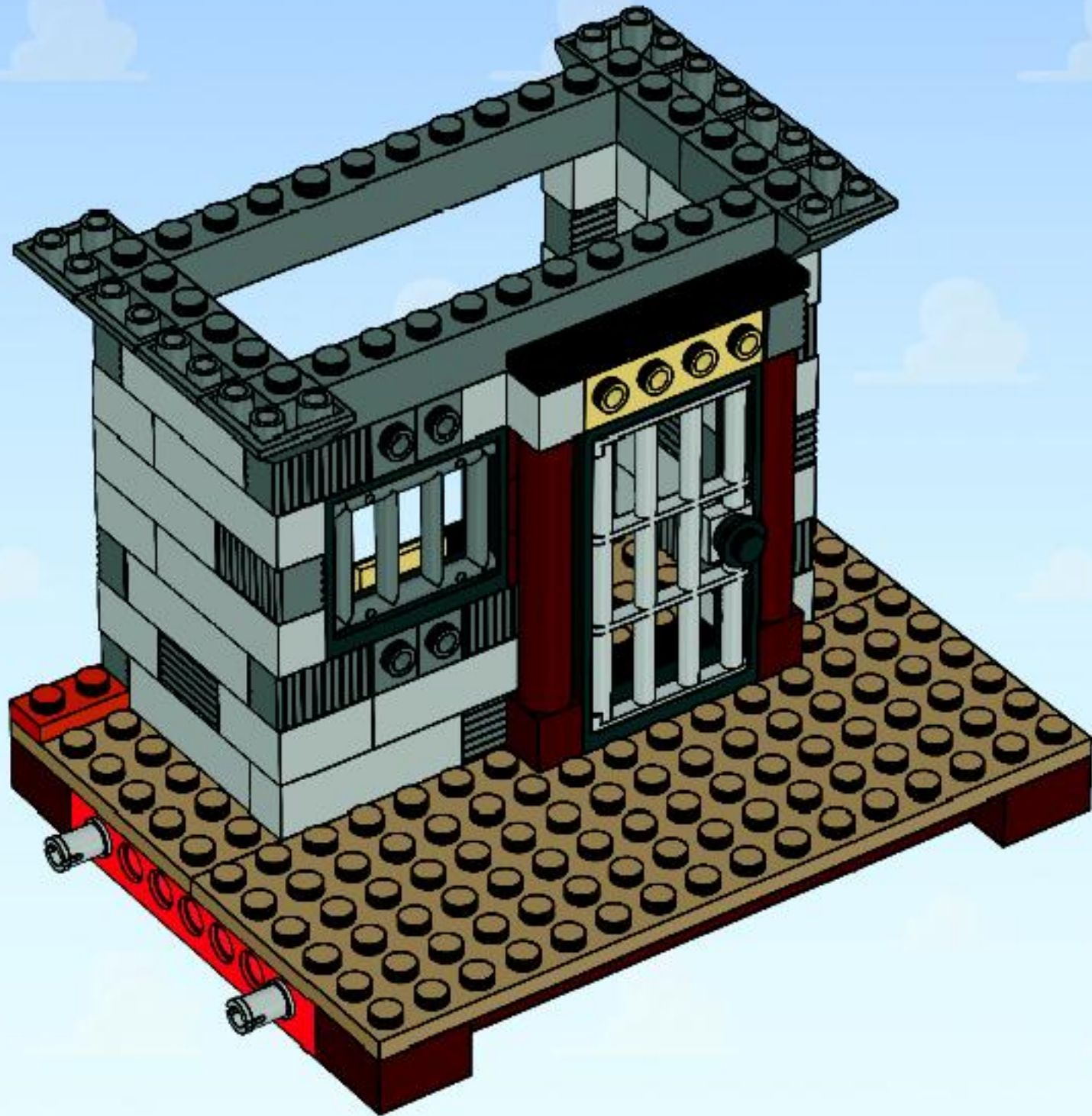

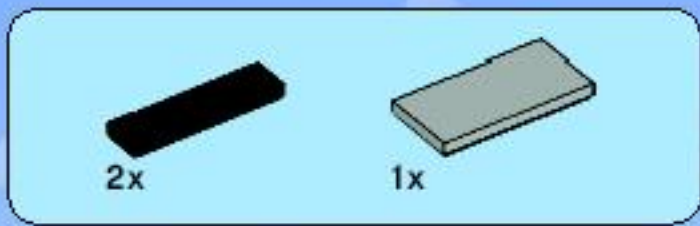

28

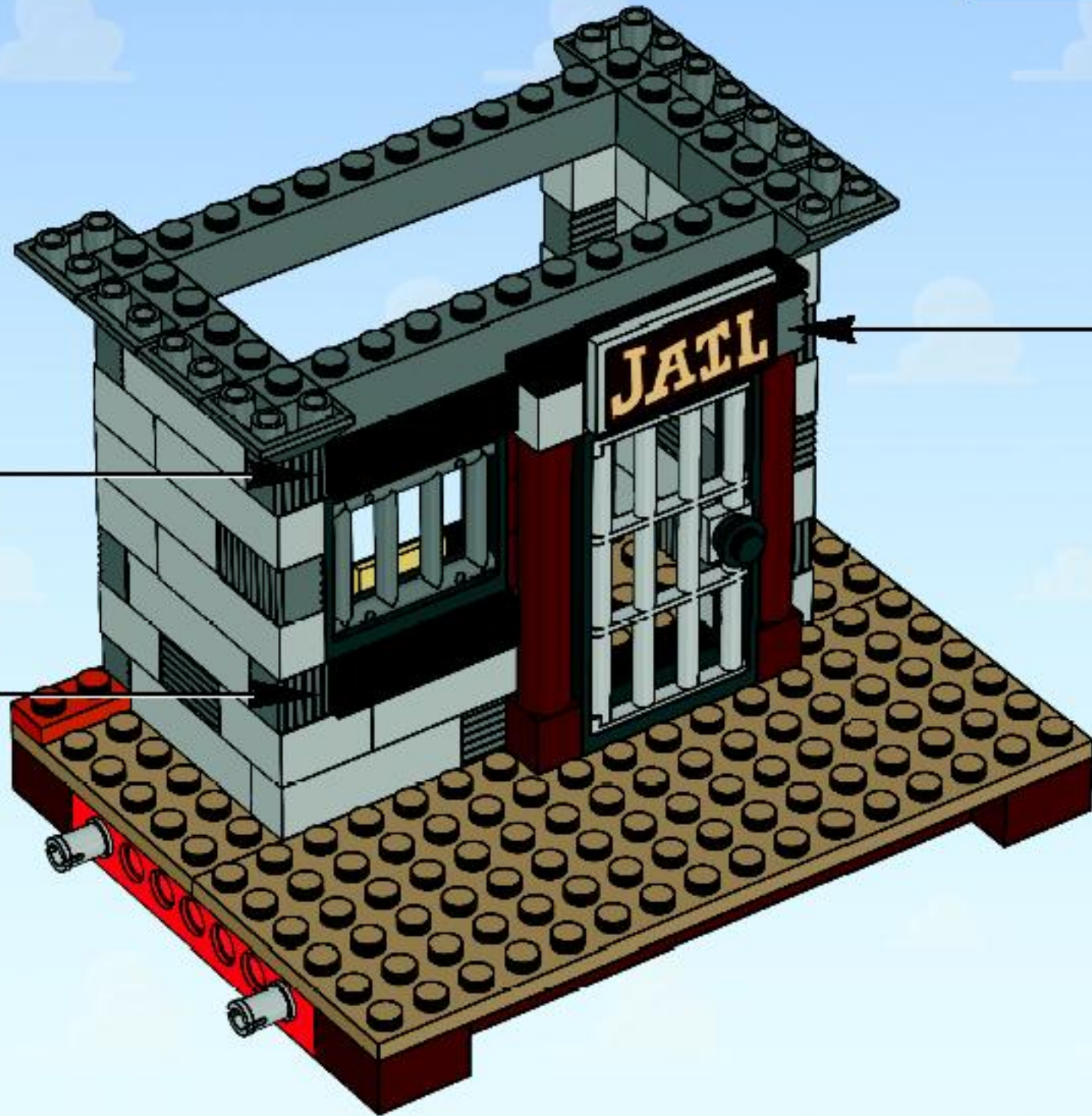
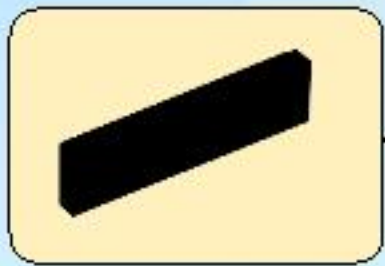

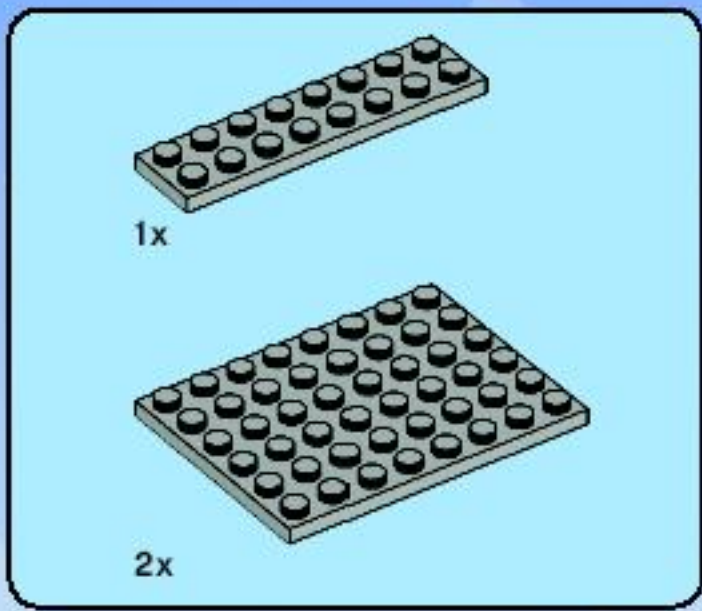

29





10x

30



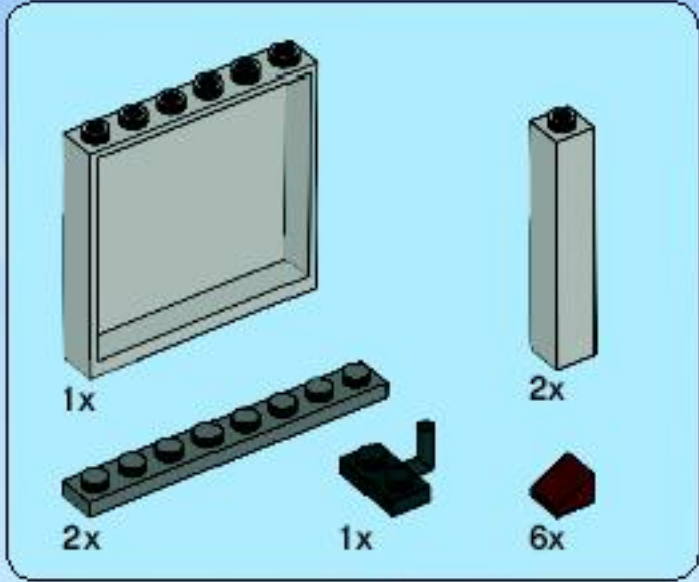
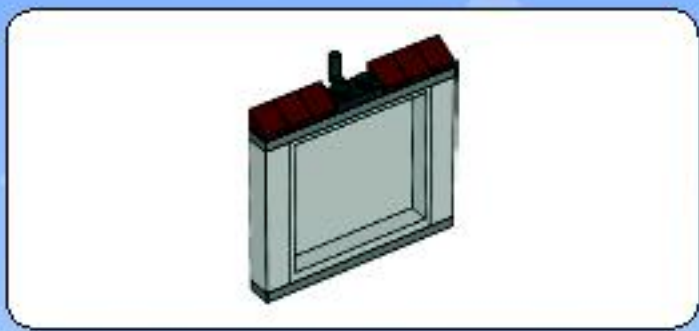

31

1

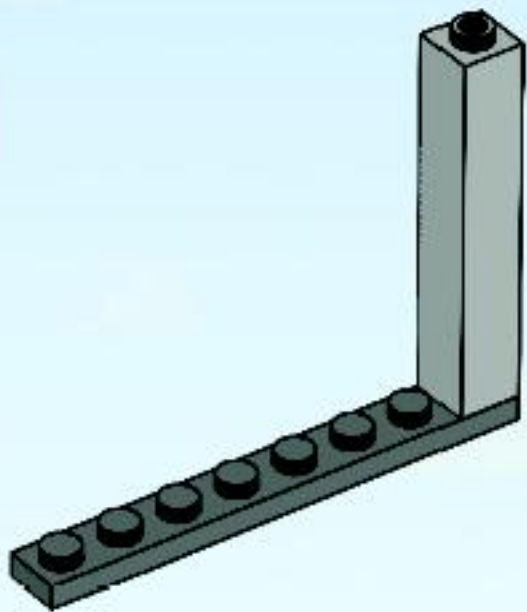

2

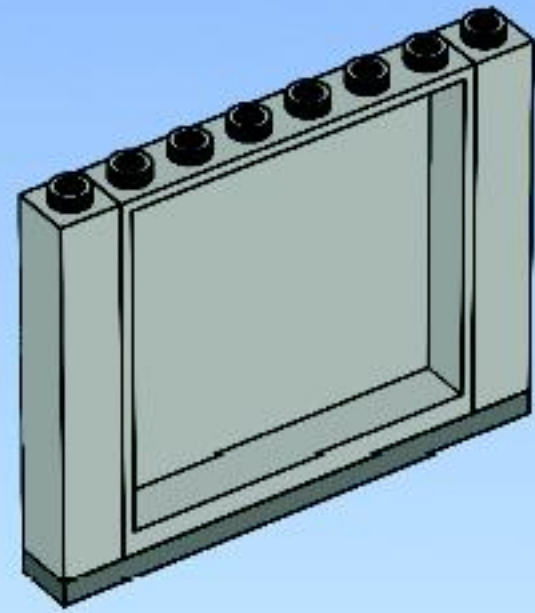

3

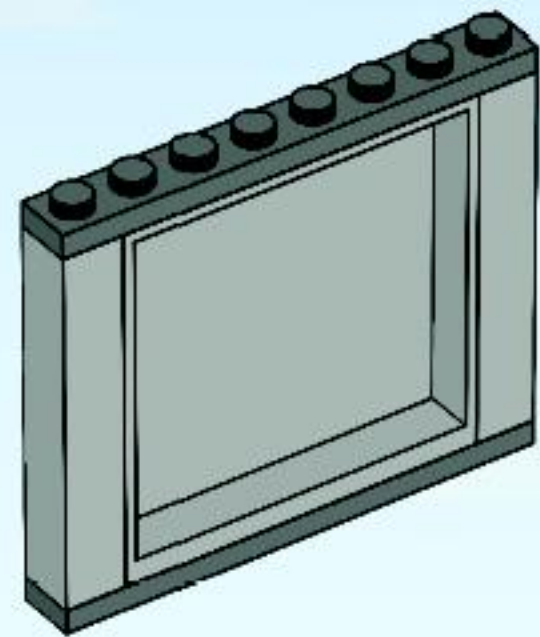

4

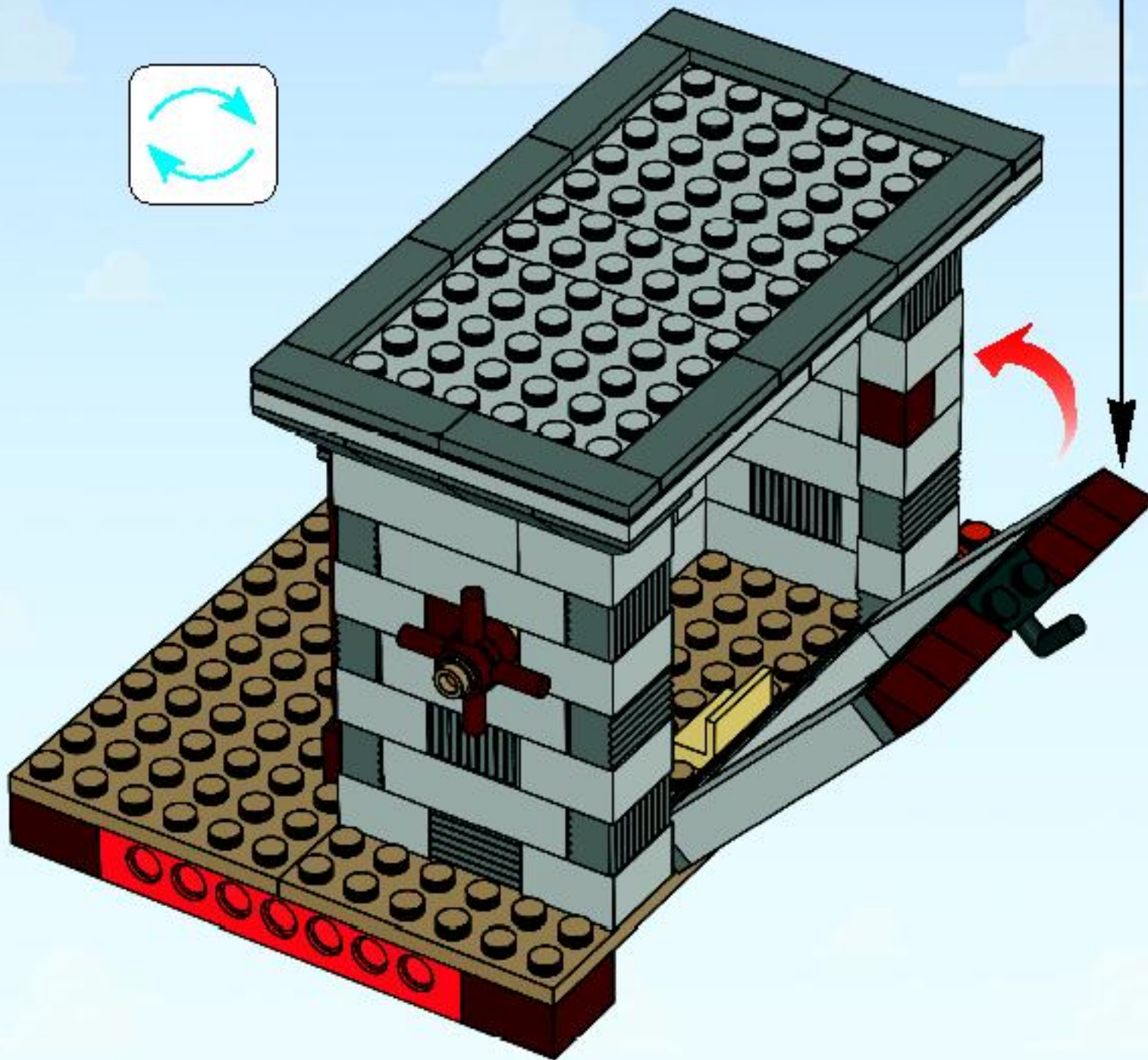
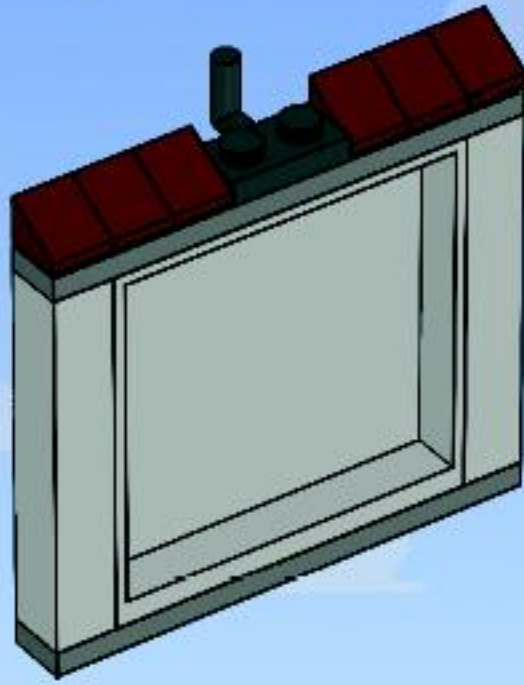

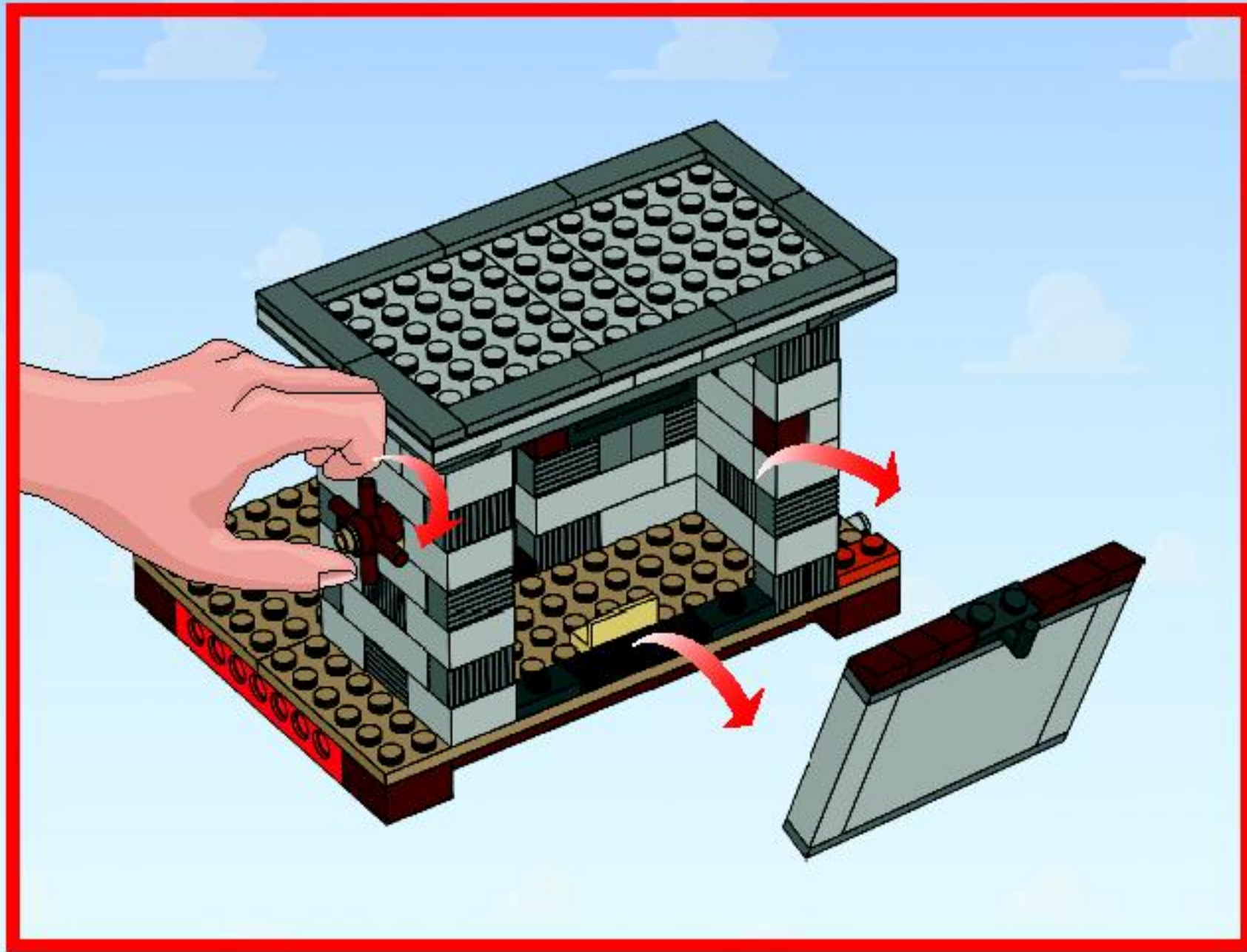



1x



2x

32

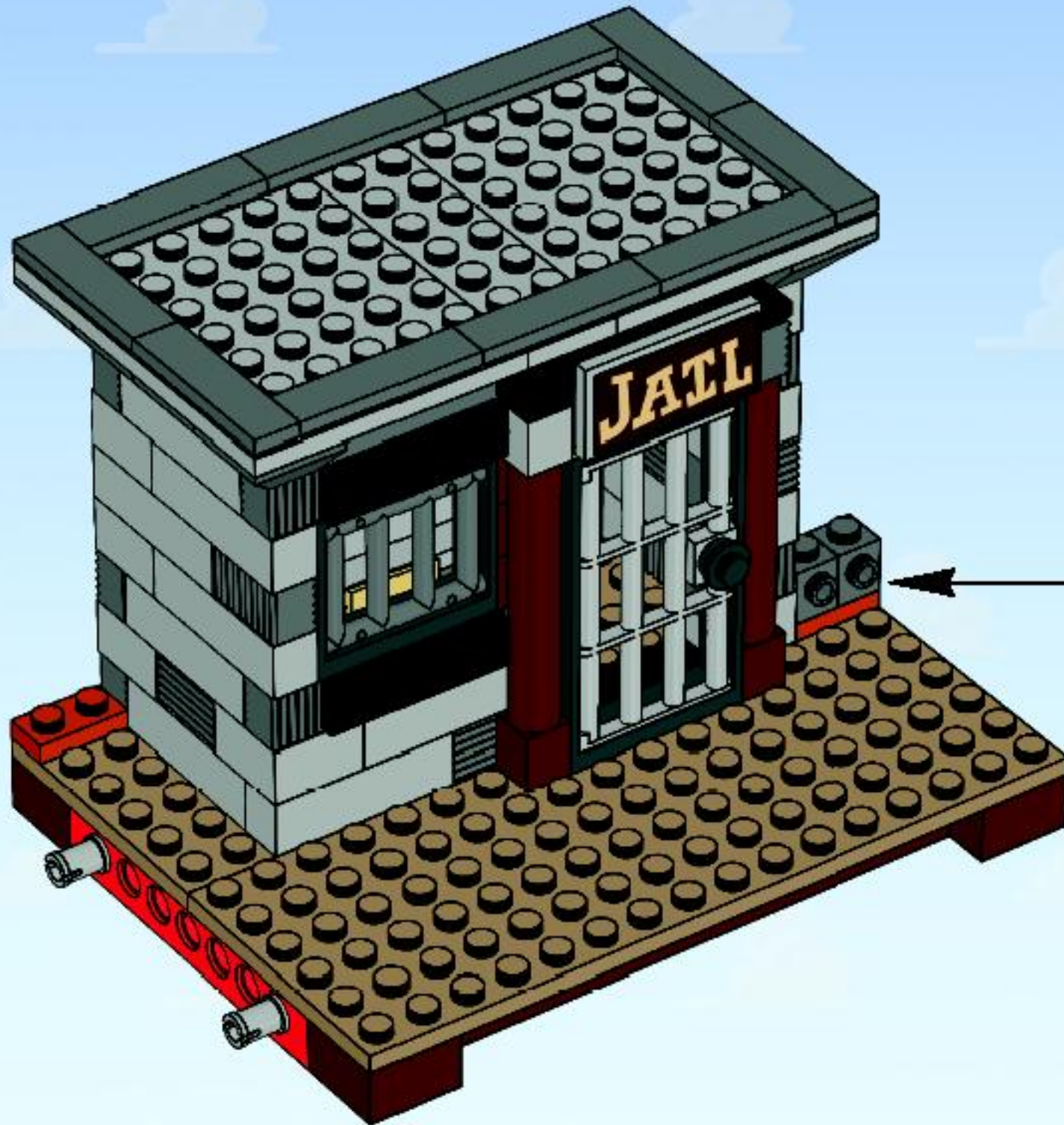

1



2





33

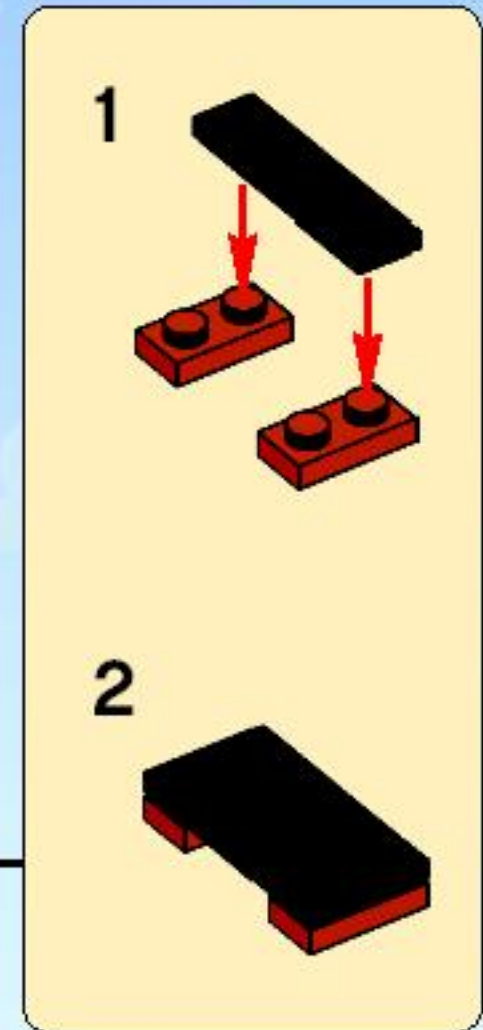
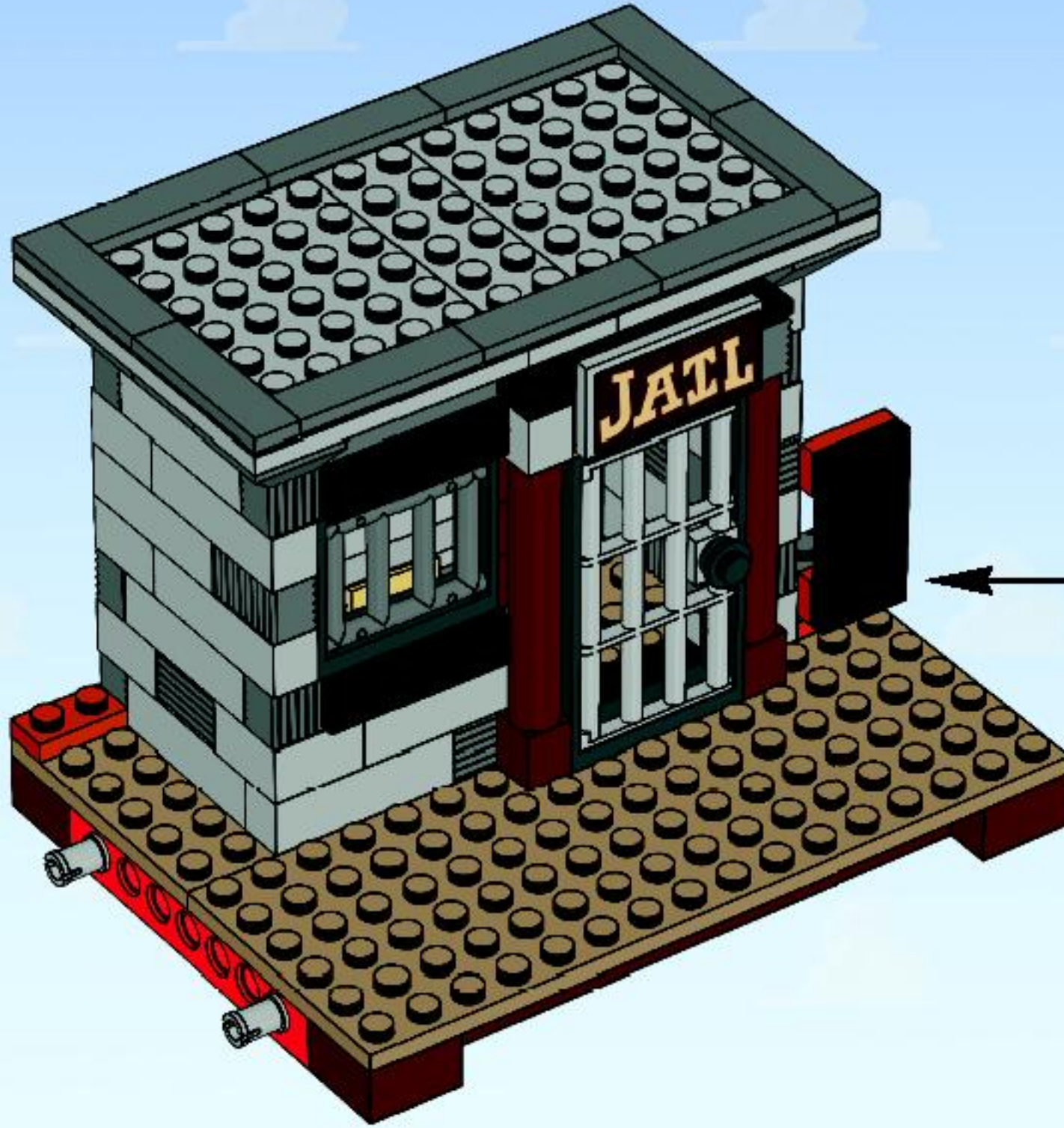

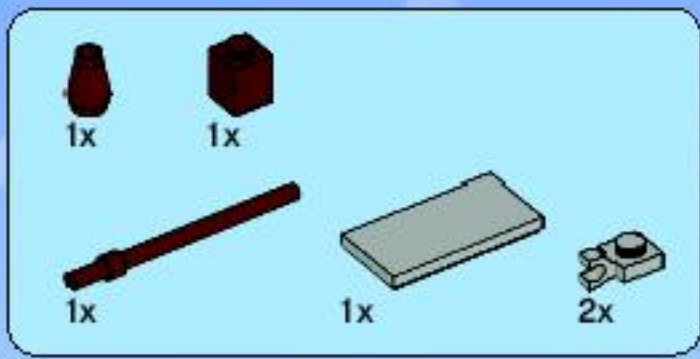

34

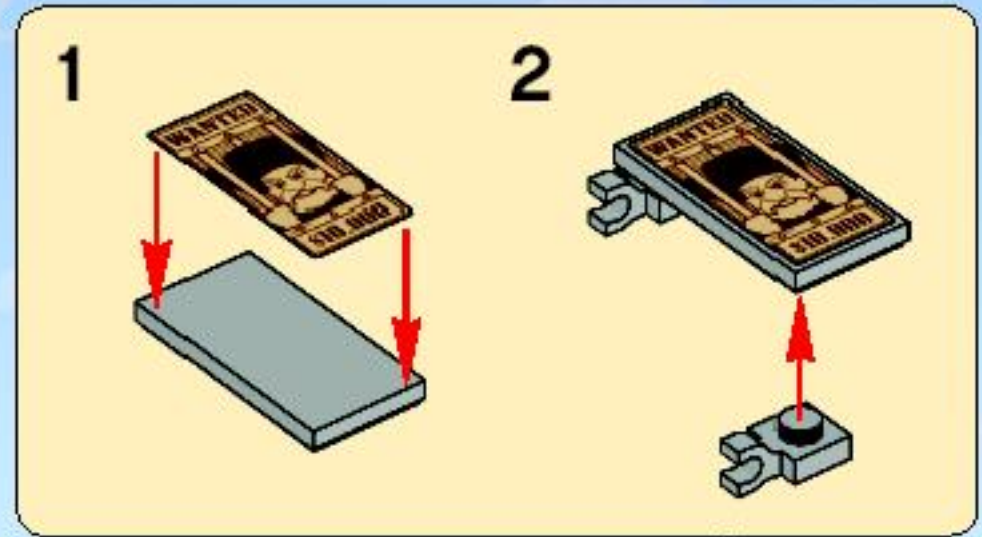
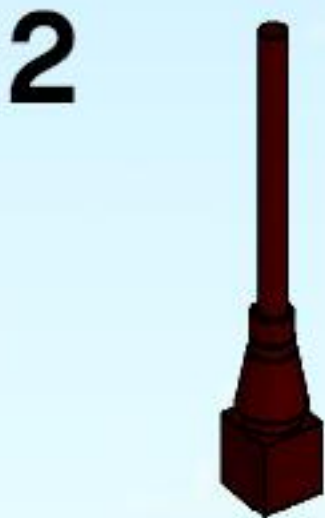
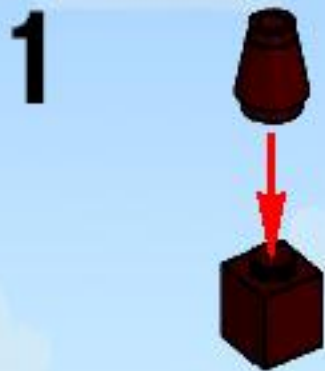

35

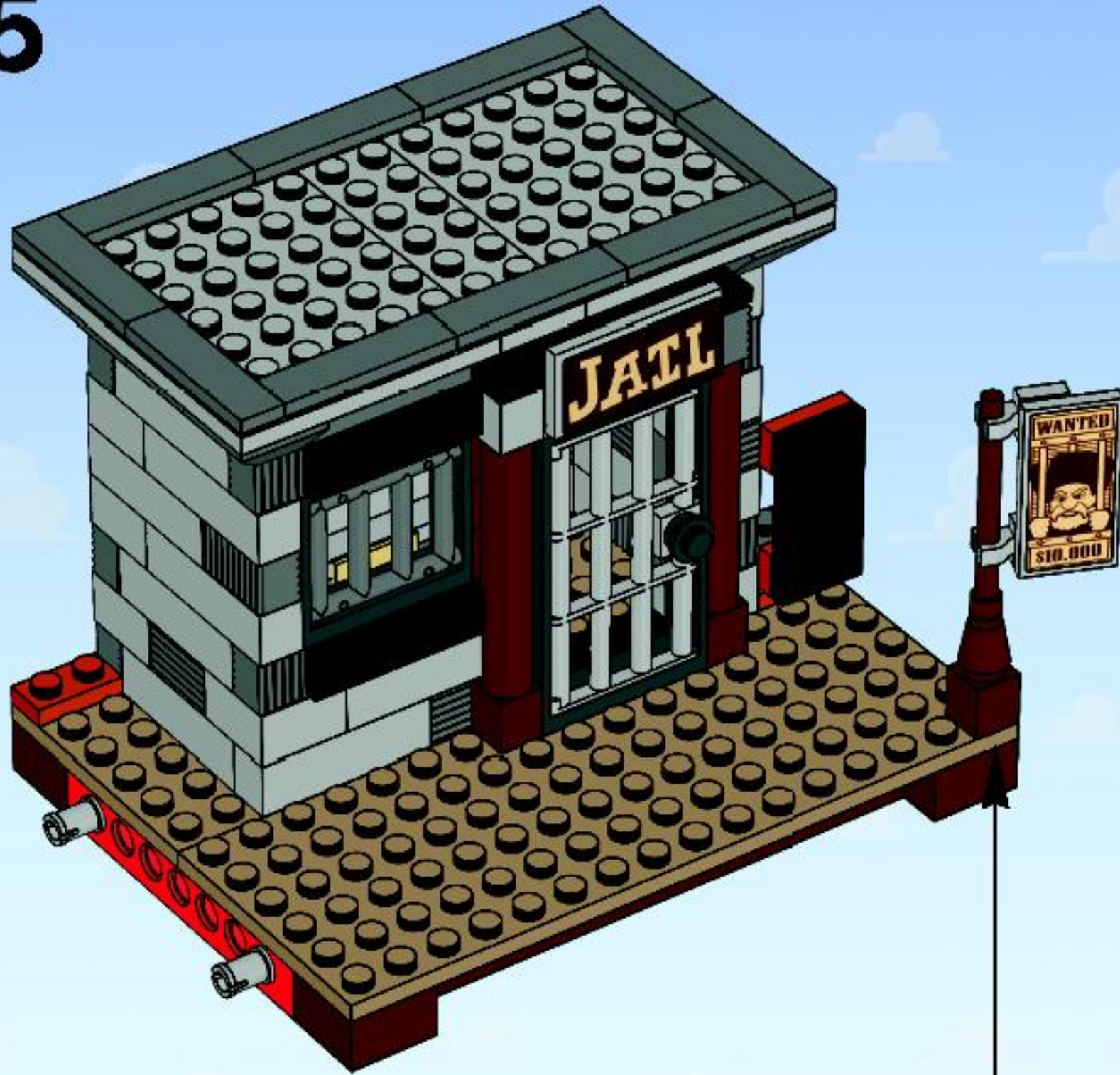



36

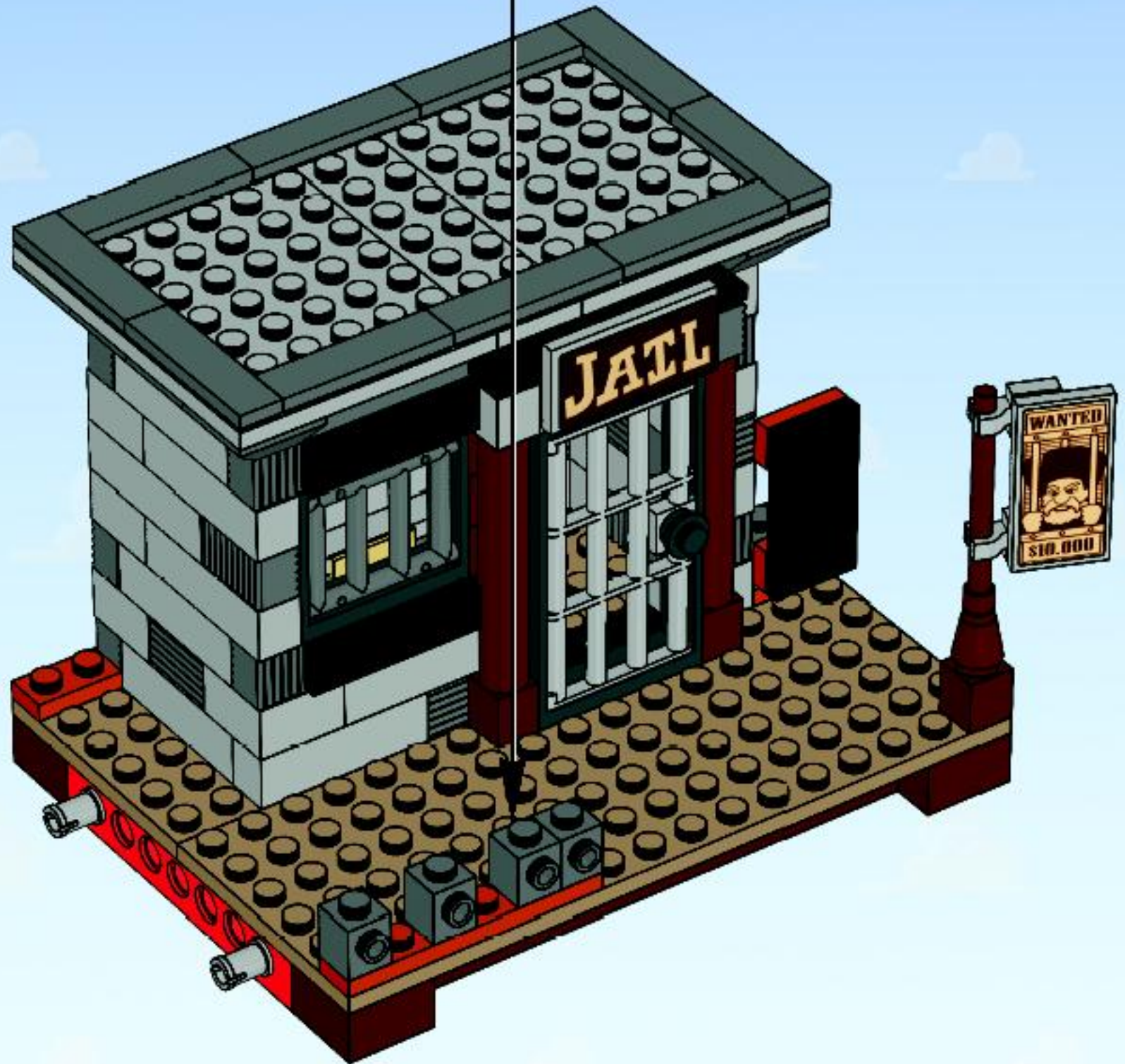
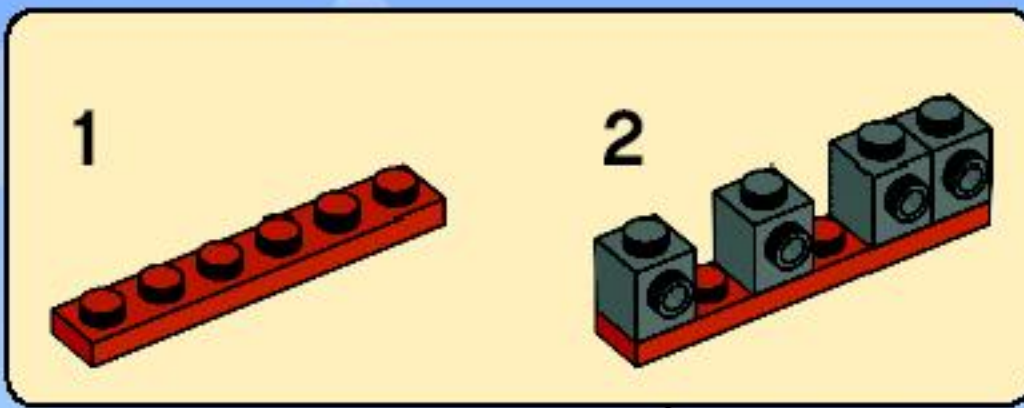



37

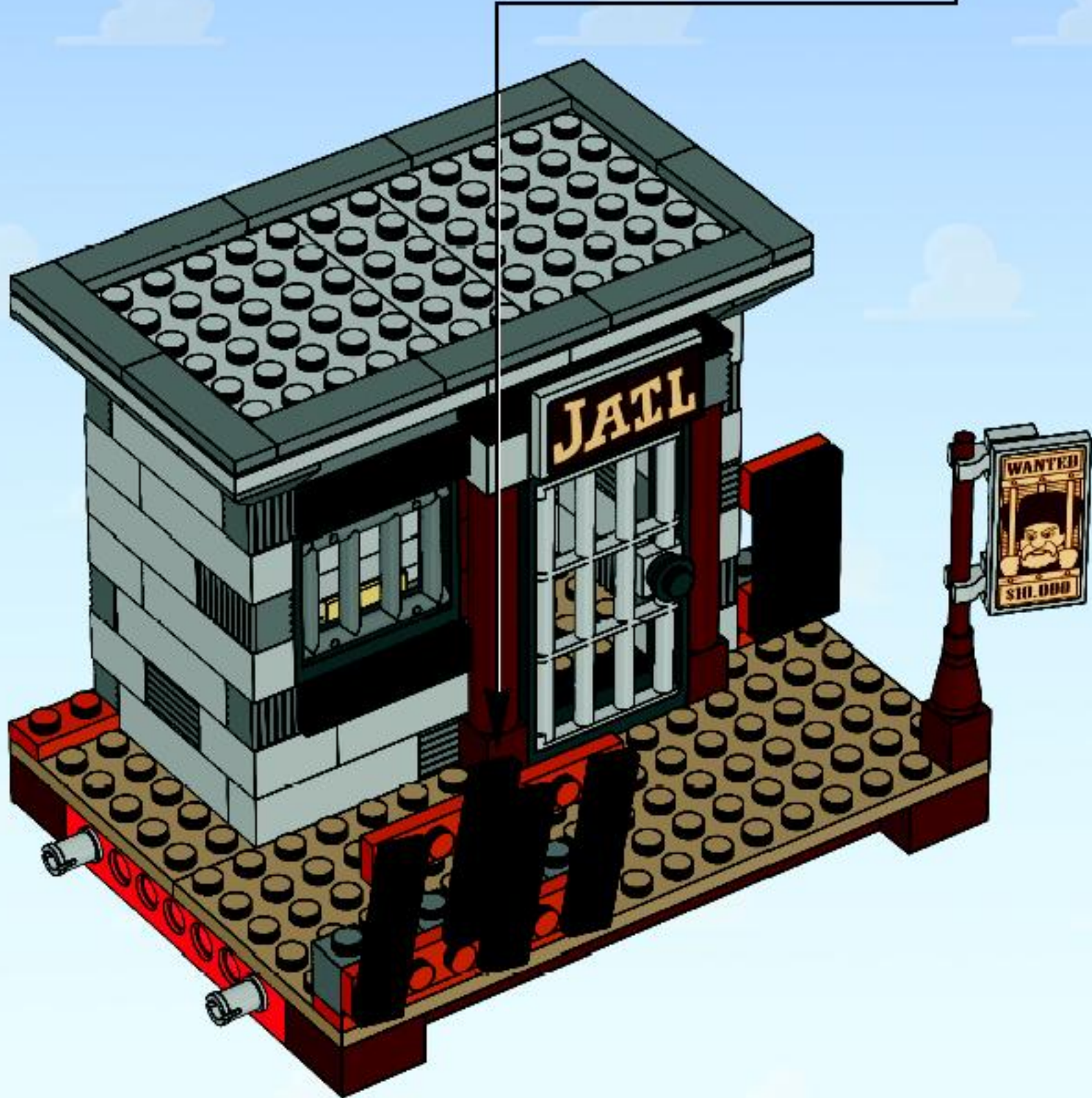
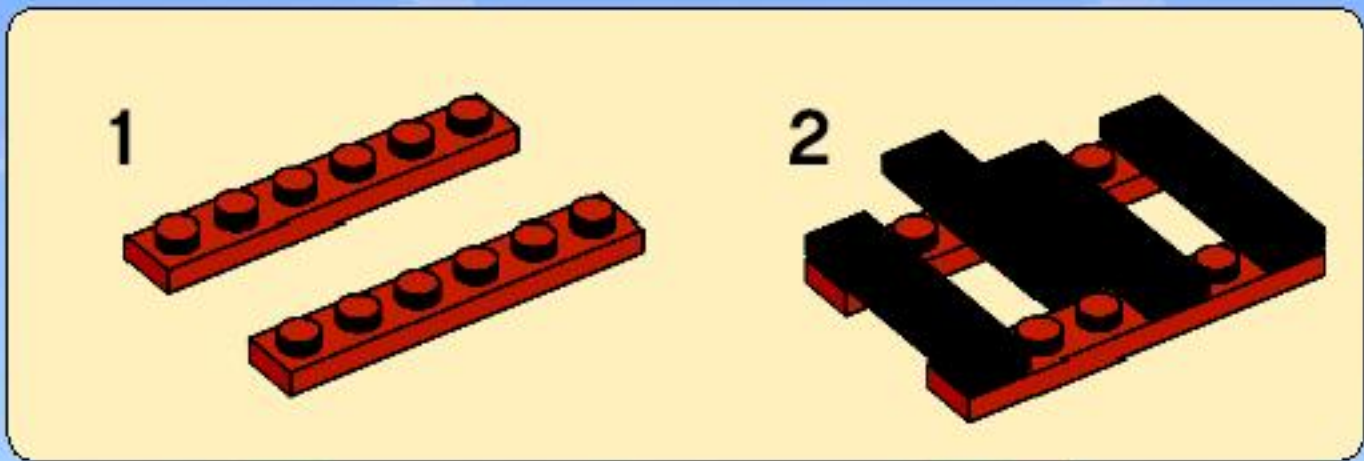

38

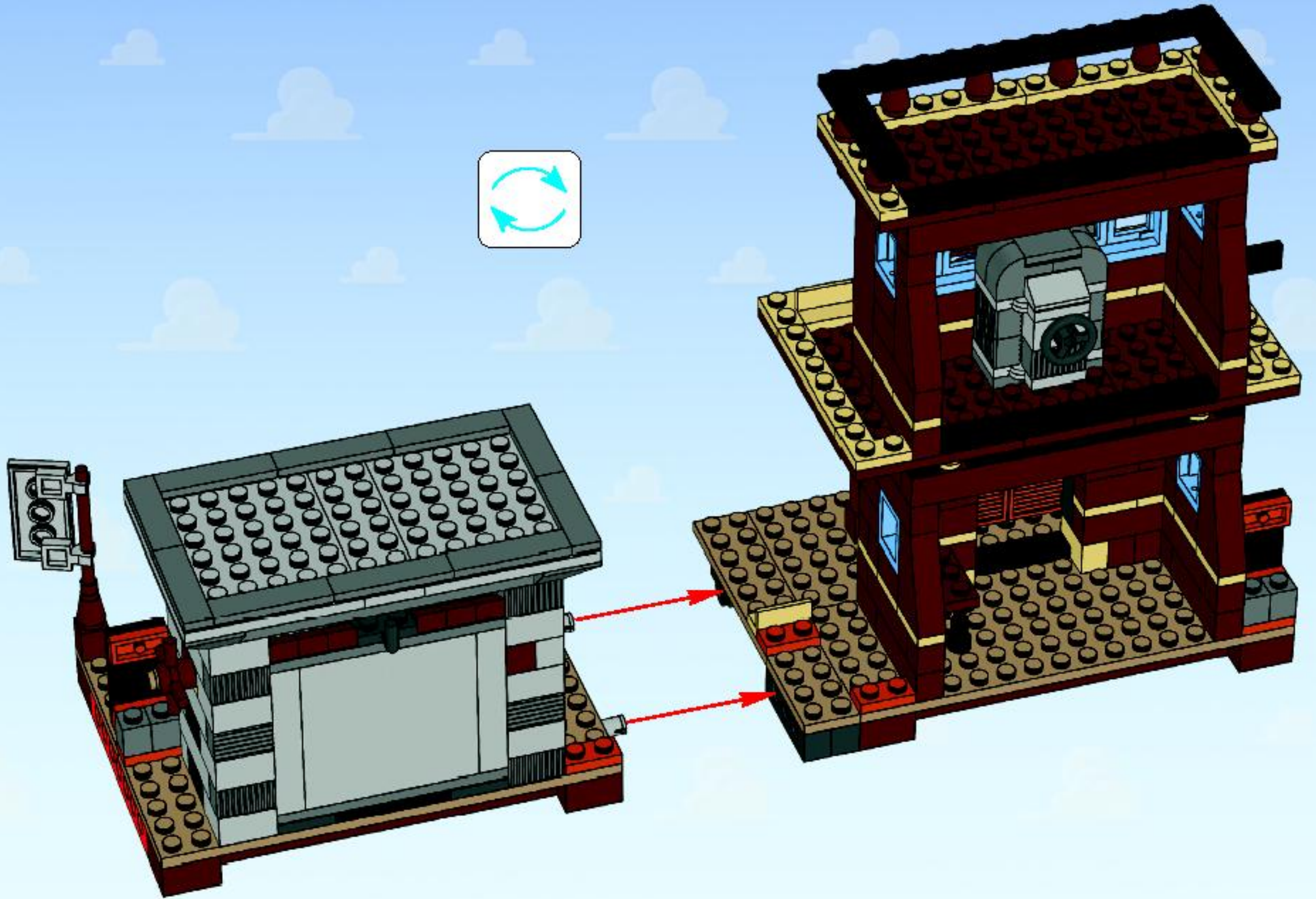

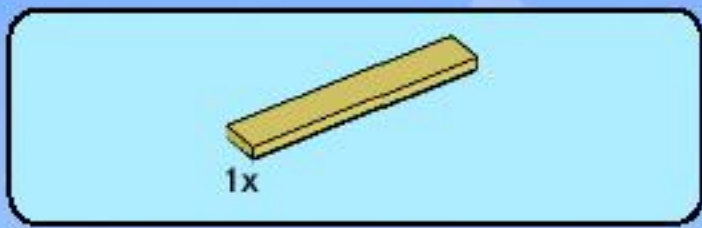

39

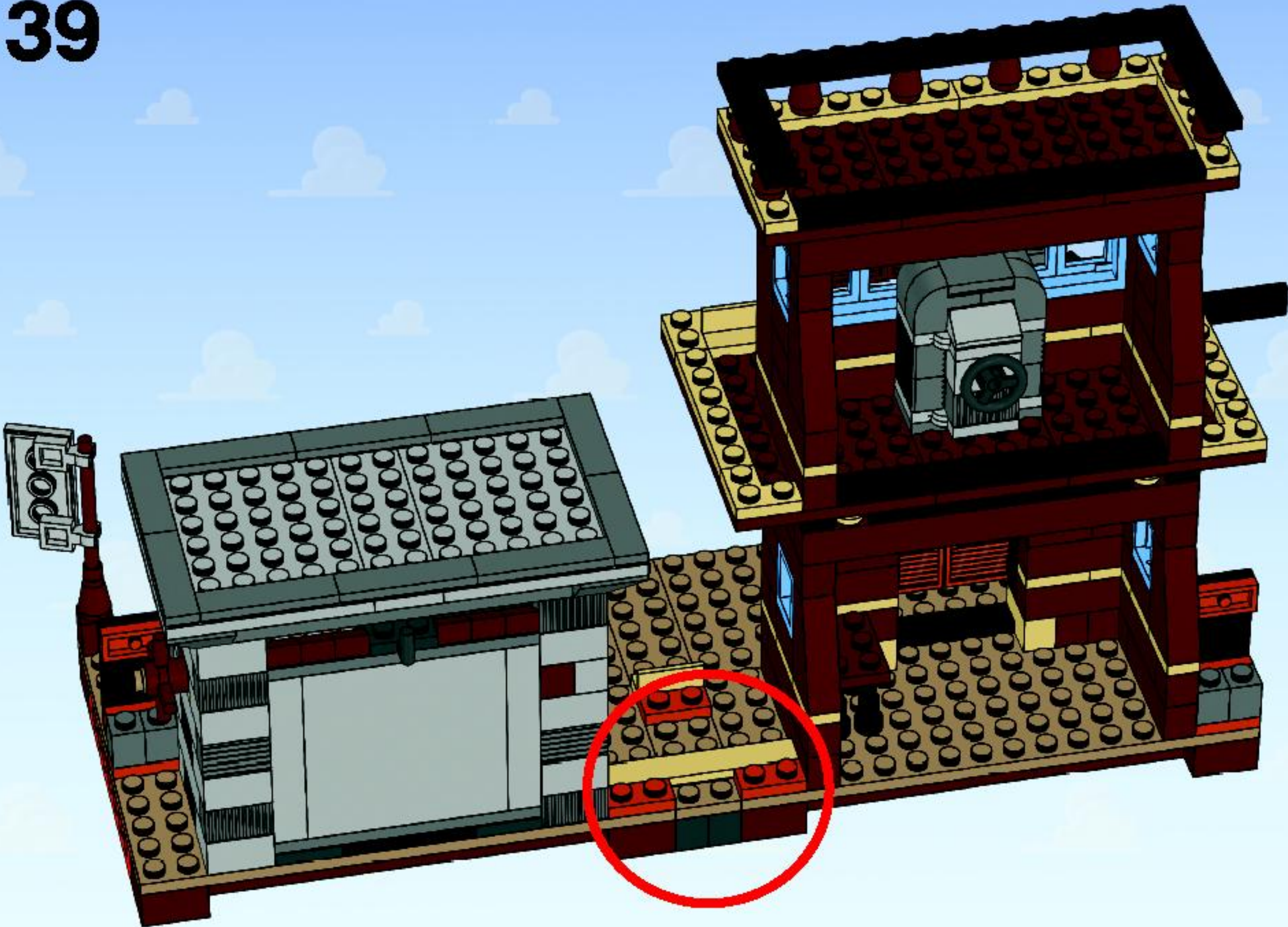



40

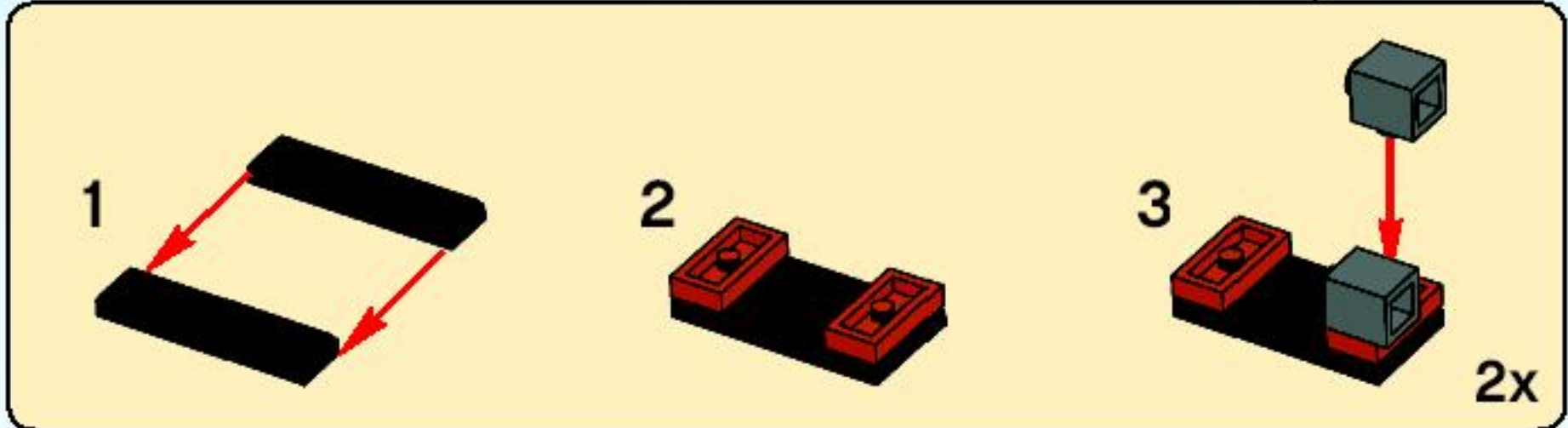
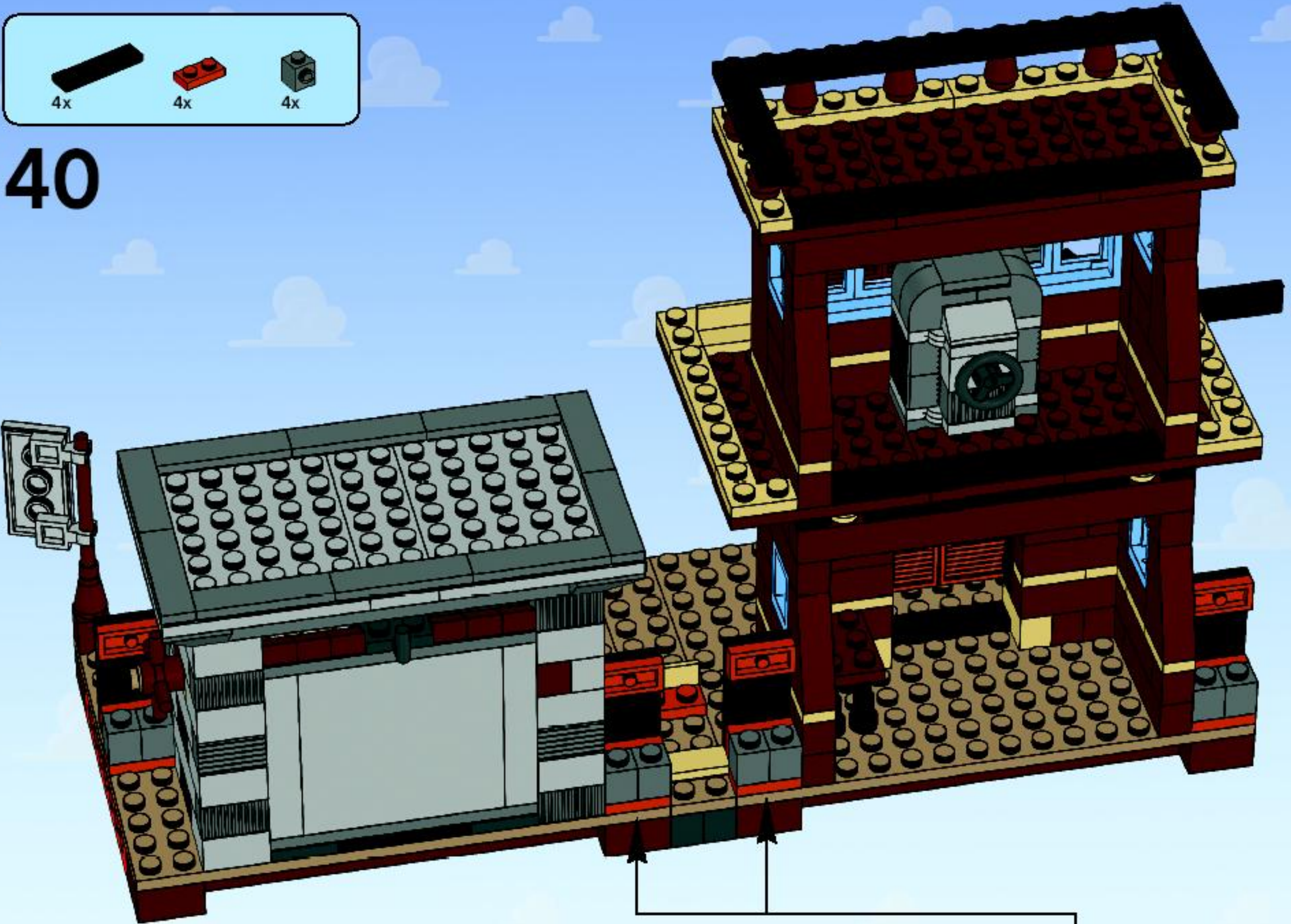







7590



7593





7591



7592





2x
4211362



4x
4211389



12x
4211349



12x
4211394



1x
4211440



5x
4568637



1x
4211410



3x
4211398



4x
4541978



2x
4219256



1x
4585529



1x
4519882



3x
4211412

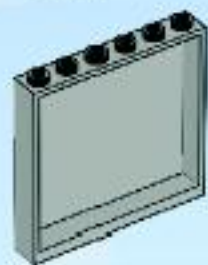

2x
4527174



1x
4518282



1x
4211375



4x
4211807



1x
4211406



2x
4211408



2x
4560183



4x
4211135



2x
4221745



4x
4210862



5x
4210702



4x
4211000



4x
4210797

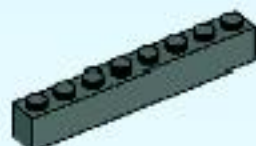

2x
4211099



2x
4211107



2x
4513326



1x
4211006



1x
4211007



1x
4211055



22x
4558955



23x
4210636



1x
4211065

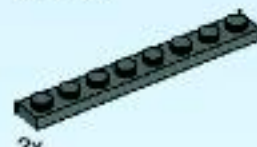

2x
4210998



1x
4521886



1x
4220973



10x
4211053



1x
4528713



10x
4566688



35x
4536989



4x
4566704



1x
4570876



4x
4538950



1x
4267874

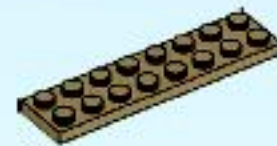

1x
4246957



1x
4566927



4x
4570878



Customer Service

Kundenservice

Service Consommateurs

Servicio Al Consumidor

www.lego.com/service or dial



00800 5346 5555 :



1-800-422-5346 :



FREE! GRATIS! GRATUIT!



www.LEGOclub.com



00800 5346 5555*

1-866-534-6258 • 1-877-518-5346
US & Canada only Canada seulement



VISIT THE WORLD'S
BIGGEST LEGO® SHOP!

www.LEGOshop.com

* Free phone, mobile charges may apply. * Numéro sans frais. Des frais peuvent s'appliquer avec les téléphones cellulaires. * Get it for free! Kosten für Anrufe aus Mobilfunknetzen können anfallen.

* Gratis telefonnummer van vaste lijn. * Débit est gratuit uniquement sur lignes Pro Pas de Frais. * Det är gratis, utifrån ringar från Post tele Fax.

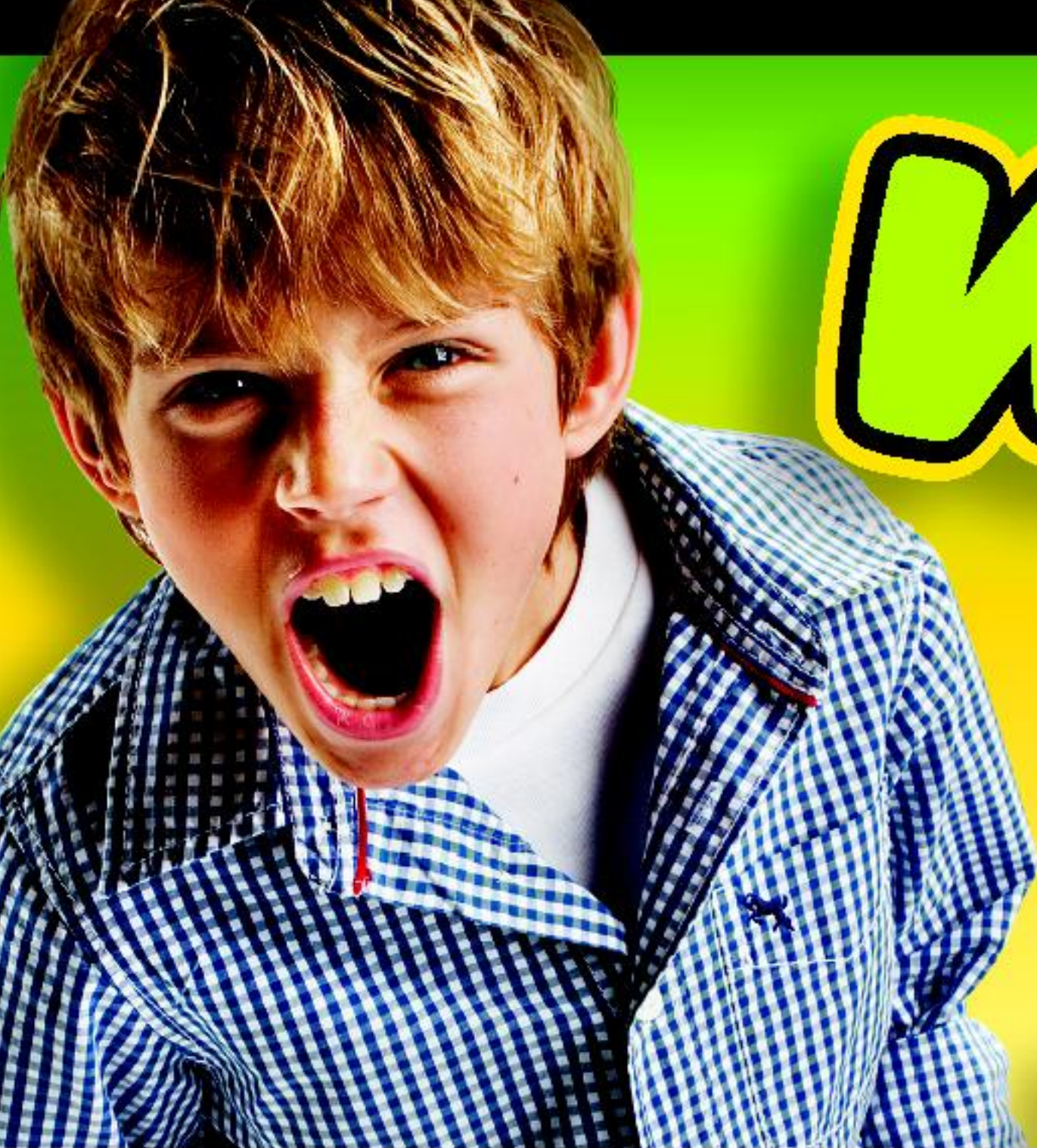

WIN!

Go to www.nielsen.com/LEGO to fill out a survey for a chance to win a cool LEGO® Product. No purchase necessary. Open to all residents where not prohibited.

 www.LEGO.com



www.nielsen.com/LEGO

GEWINNE! WIN!

Nimm an der Umfrage auf www.nielsen.com/LEGO teil und hab die Chance ein cooles LEGO® Produkt zu gewinnen!

Die Teilnahme am Gewinnspiel führt zu keinerlei Kaufverpflichtungen. Teilnahme in allen nicht ausgeschlossenen Ländern möglich.

Ga naar www.nielsen.com/LEGO, vul een enquêteformulier in en maak kans op een cool LEGO® product.

Geen aankoopverplichting. Iedereen mag deelnemen, uitgezonderd ingezetenden van landen waar een enquêteverbod geldt.

GAGNE! 当てよう!

Visite www.nielsen.com/LEGO pour répondre à un questionnaire et avoir une chance de gagner un produit LEGO® très cool!

Aucune obligation d'achat. Ouvert à tous les résidents des pays autorisés.

www.nielsen.com/LEGOにアクセスして、アンケートにご記入ください。当選者にはレゴ製品を差し上げます。

お買い上げの必要はありません。

禁止されていない限り、すべての賞品にご利用いただけます。